

# Roomba® Max 705

**Vac** Robot + AutoEmpty™ Dock

Owner's Guide

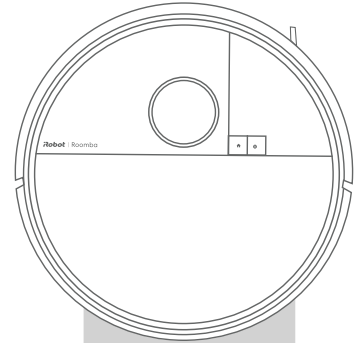

**iRobot**

# Getting started

- 1 Remove protective film from camera and foam inserts behind bumper

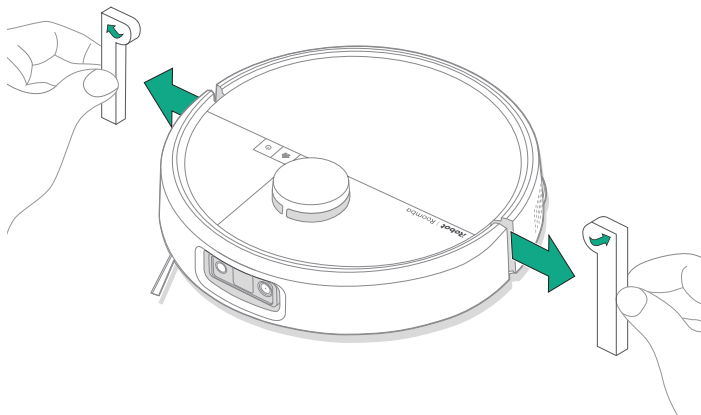

- 2 Place the dock on hard surface flooring

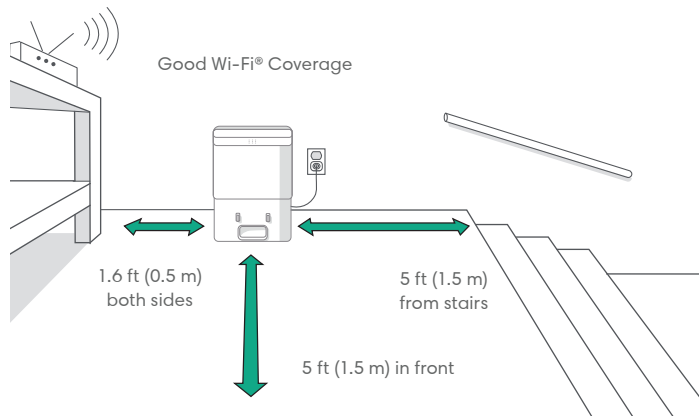

**NOTE:** Do not place it in direct sunlight. Ensure the area around the dock is free of clutter to improve docking performance.



**WARNING:** To prevent the risk of your robot falling down stairs, ensure that your dock is placed at least 5 feet (1.5 meters) away from stairs.

### 3 Plug in the dock

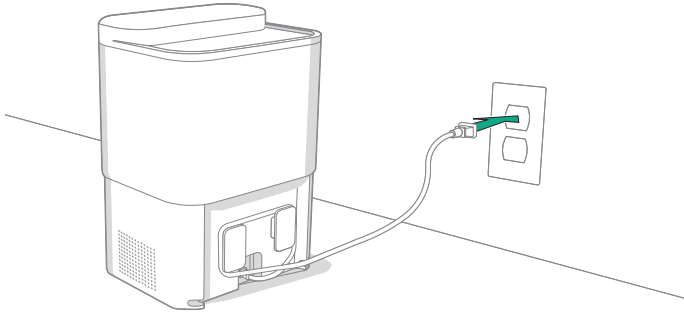

Plug the power cord into the wall. Wrap the cord back so it won't get in the way of the robot as it comes and goes.

### 4 Install the Edge-Sweeping Brush

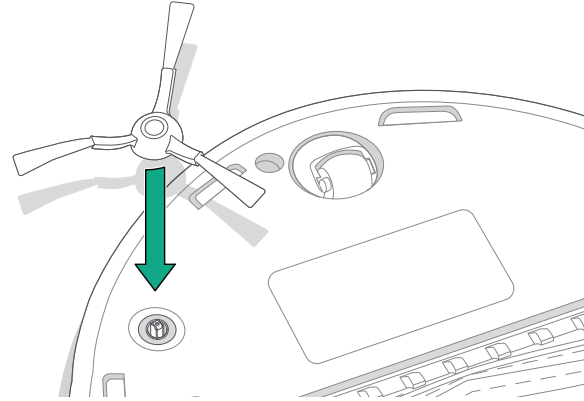

Align the edge-sweeping brush and press down until you hear a click.

## 5 Wake up the robot

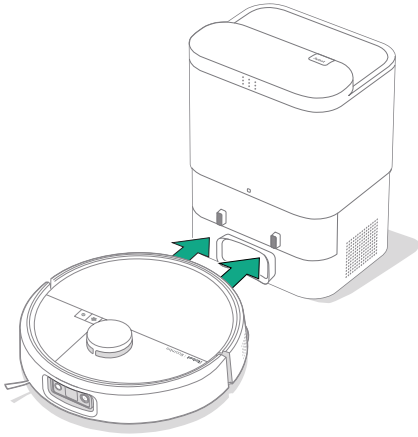

Place your robot in front of the dock, then slide it toward the dock, lining up the metal charging contacts. After a few minutes, a sound will let you know it's awake.



**NOTE:** Your robot comes with a partial charge, but we recommend that you charge the robot for 4 hours prior to starting the first cleaning.

To remove your robot from the dock, slide the robot towards you and then lift.

## 6 Download the Roomba® Home App

Scan the QR code with the camera on your mobile device or find the Roomba® Home App in your app store. The app will guide you through steps to setup your robot. Once your robot is set up in the app, you'll be able to:

- Control when, where, and how you clean
- Create automatic cleaning schedules
- Set custom cleaning preferences
- Unlock digital features
- Access to tips, tricks, and answers to commonly asked questions



**IMPORTANT:** Read enclosed safety information guide first before using your robot.

# About your Roomba® Max 705 Vac

## Top View

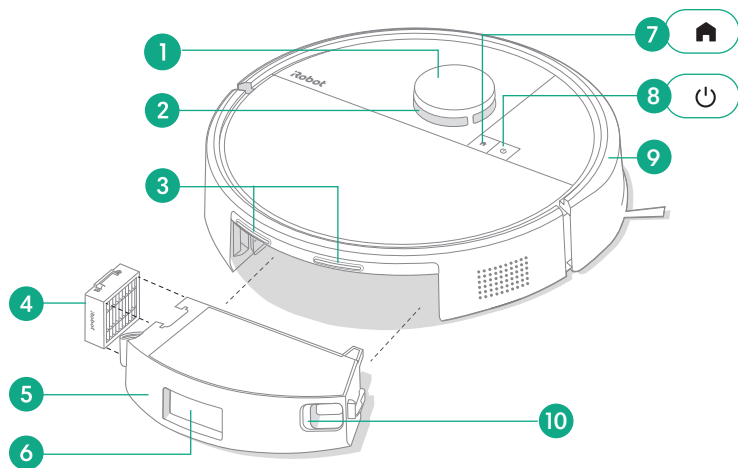

- 1 LiDAR Detector Bumper
- 2 ClearView™ Pro LiDAR
- 3 Charging Contacts
- 4 Filter
- 5 Bin

- 6 Debris Evacuation Port
- 7 Home Button
- 8 Power Button
- 9 Bumper
- 10 Bin Release Button

## Bottom View

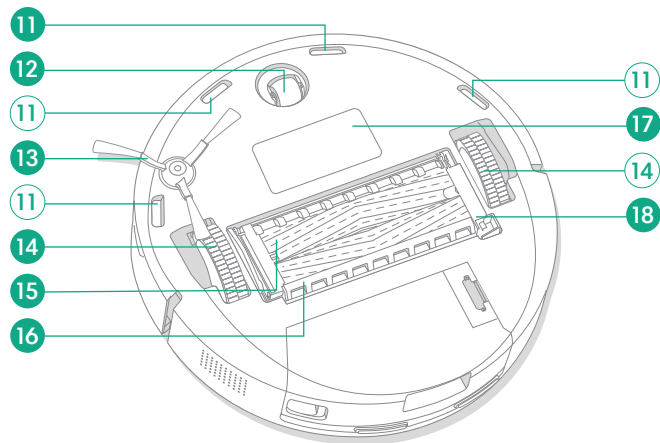

- 11 Cliff Sensors
- 12 Caster Wheel
- 13 Edge-Sweeping Brush
- 14 Wheels
- 15 Multi-Surface Rubber Brushes

- 16 Brush Cover
- 17 Battery Pack
- 18 Brush Cover Release

# About your AutoEmpty™ Dock for your Roomba® Max 705 Vac

Front View

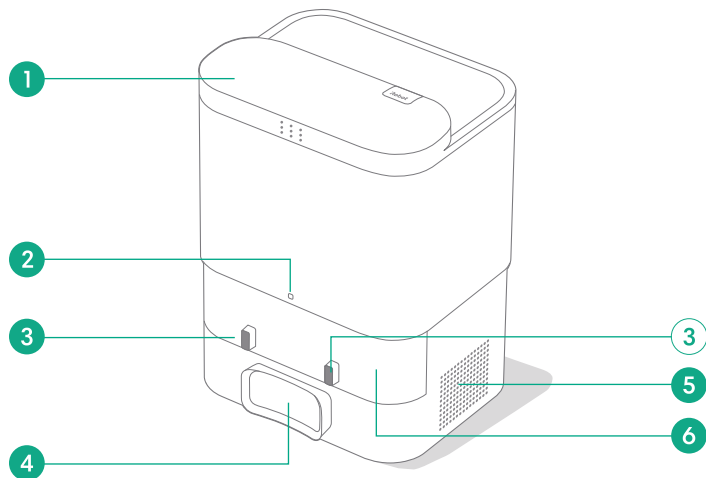

- 1 Canister Lid
- 2 LED Indicator
- 3 Charging Contact
- 4 Debris Evacuation Port
- 5 Exhaust Vent
- 6 IR Window

Top View

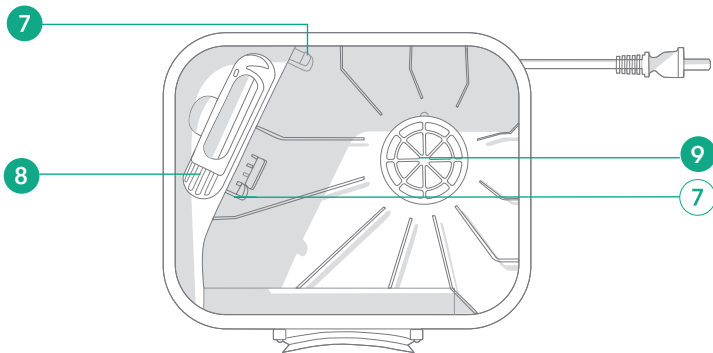

- 7 Bag Guide Rails
- 8 Cleaning Brush Accessory
- 9 Dock Filter

# Charging

## Power Icon Indicator

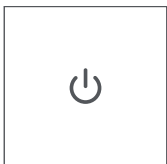

### POWER Button

**White** - Fully charged and connected

**Flashing White** - Return to dock to charge

**Pulsing White** - Charging (low battery) -

If the user tries to start a mission the buttons will then FLASH Red and trigger an audio telling users it can't start due to low battery.

**Flashing Red** - Low battery/Error

## Dock LED Indicator

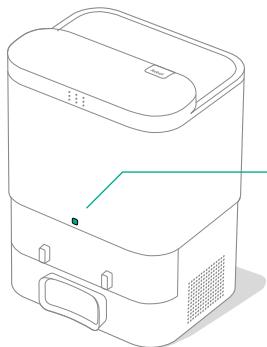



**Solid White:** Charging

**Solid Red:** Bag full or not installed

## Charging during a cleaning routine

You robot will return to the dock whenever it needs to recharge. Once it is sufficiently charged, it will then resume cleaning where it left off.

## Standby mode

Your robot uses a small amount of power whenever it is on the dock. You can put it in a further-reduced power state when not in use by pressing  for 10 seconds. To exit low power mode short press  button.

## Storing your robot

For long-term storage, turn off your robot by removing it from the dock and holding  for 10 seconds. Store in a cool, dry place.

# Cleaning

## Button Controls



**HOME button:** Tap to send the robot home

Press when running to pause

Press when paused to dock

Press when docking to stop

Press when docked to empty the dust bin

**POWER button:** Tap to Start / Pause / Resume a job

Hold for 3 seconds to turn on

Hold for 10 seconds to turn off

## Cleaning Pattern

Your robot will automatically explore and clean your home in neat rows. It will return to the dock at the end of a cleaning routine whenever it needs to recharge.





**Tips:**

- Remove excess clutter from floors before cleaning.
- Use your robot frequently to maintain well-conditioned floors.

After 90 minutes of inactivity off the dock, your robot will automatically end its cleaning. If you are unsure if it is finished or paused, visit the **Roomba® Home App** to check on its status.

## Spot clean

Tap  button two times to spot clean a designated area. After spot clean is complete, your robot will end the job. Press  To send it back to its dock.

## AutoEmpty™ Dock

Your robot will automatically attempt to empty its dust bin every time it returns to its AutoEmpty™ Dock, or is physically placed on the AutoEmpty™ Dock.



**NOTE:** It is highly recommended to use the Roomba® Home App for cleaning control. The mobile app can be used to clean specific rooms, setup cleaning routines, and create automations/schedules.

# Vacuuming

- 1 To start cleaning, place the robot back on dock and use the app or press the  button.

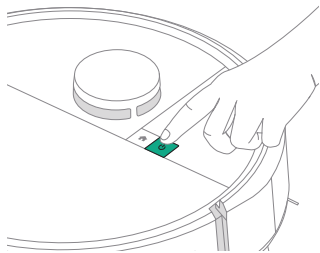

**NOTE:** It is recommended to clean the dust bin at least once a week. Otherwise, the performance of the vacuum may be reduced.

# Care and maintenance for your robot

To keep your robot at optimal performance, make sure you periodically perform the following basic care & maintenance. There are additional instructional videos in the Roomba® Home App. If you notice your robot picking up less debris from your floor, empty the bin, clean the filter, and clean the brushes.

Part	Care Frequency	Replacement Frequency*
Dust bin	Empty bin as needed	-
Filter	Clean once a week (twice a week if you have a pet)	Every 2 months
Edge-sweeping brush	Clean every 2 weeks or as needed	Every 3-6 months
Multi-surface rubber brushes	Clean once a week	Every 6-12 months
Front caster wheel	Clean every 2 weeks or as needed	-
Charging contacts	Clean every 2 weeks or as needed	-
Sensors	Clean once a month or as needed	-
Brush cover	Inspect every 6 months	Replace if worn or damaged

\* Replacement frequency may vary. Parts should be replaced if visible wear appears. If you think you need a replacement part, please contact iRobot Customer Care for more information.

## Cleaning the Edge-Sweeping Brush

Pull to remove the edge-sweeping brush. Remove any hair or debris using the cleaning brush, then reinstall the edge-sweeping brush.

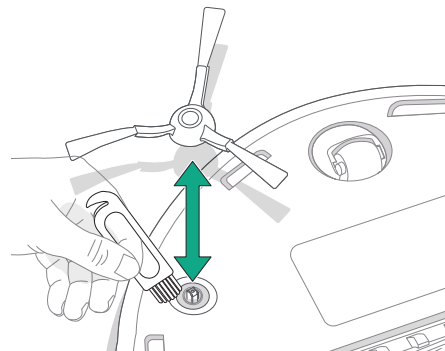

**IMPORTANT:** It is recommended to replace the edge-sweeping brush every 3-6 months for an optimal cleaning effect.

## Cleaning the Multi-Surface Rubber Brushes

- 1 Pinch the brush frame release tab, lift the tab, and remove any obstructions.

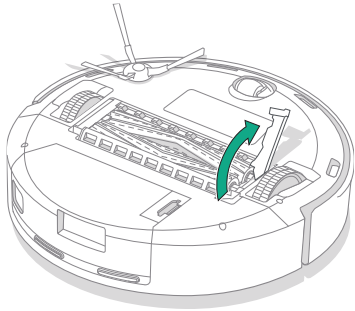

- 2 Remove the multi-surface rubber brushes.

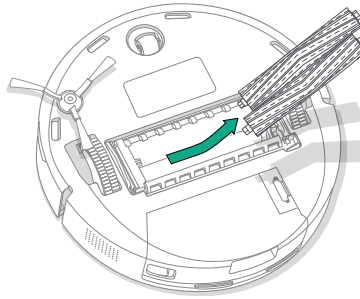

- 3 Remove the end caps from the ends of the brushes.

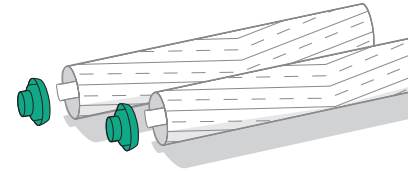

- 4 Remove any hair or debris that has collected beneath the caps. Replace end caps.

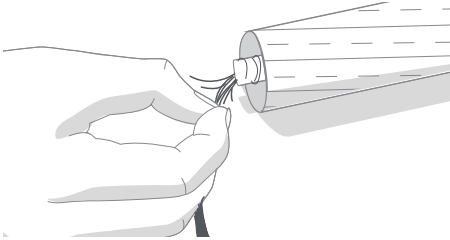

- 5 Reinstall the multi-surface rubber brushes and brush cover in the robot.

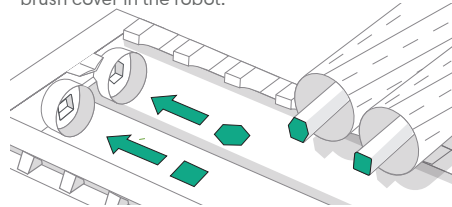

**IMPORTANT:** It is recommended to replace the multi-surface brushes every 6-12 months for an optimal cleaning effect.

## Cleaning the Front Caster Wheel

Use the cleaning brush to remove hair and debris from the front caster wheel.

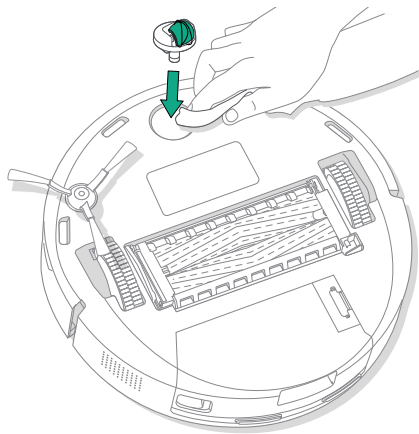

**IMPORTANT:** A front wheel clogged with hair and debris could result in damage to your floor. If the wheel is not spinning freely after you have cleaned it, please contact Customer Care.

## Cleaning the Charging Contacts and Sensors

Unplug dock from wall and wipe charging contacts and sensors with a clean, dry cloth or lightly dampened melamine foam.

### CHARGING CONTACTS

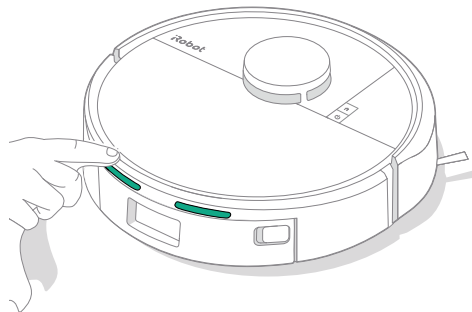

### SENSORS

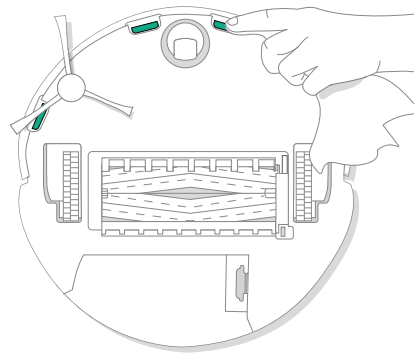

**IMPORTANT:** Do not spray cleaning solution or water onto the sensors or sensor openings.

## Emptying the Bin

- 1 Press the dust bin release buttons to remove dust bin.

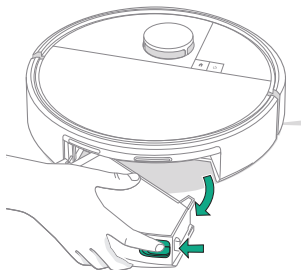

- 2 Open door to empty and clean dust bin with cleaning brush.

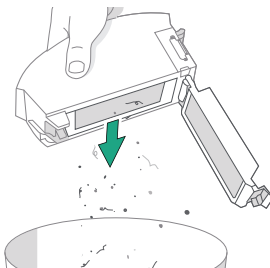

- 3 Clean debris from vacuum path. Place bin back in the robot.

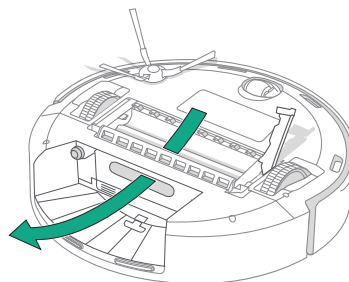

## Washing the Bin

- 1 Release the bin, remove the filter, and open the bin door.

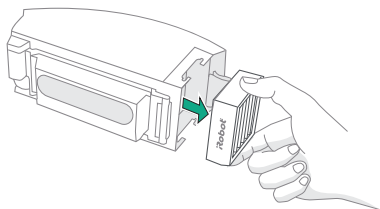

- 2 Rinse the dust bin and water tank using warm water.

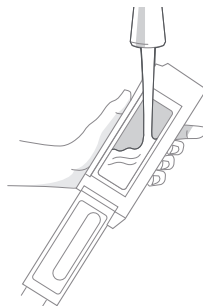

- 3 Make sure bin is completely dry. Reinsert filter and place bin back in the robot.



**IMPORTANT:** The bin is not dishwasher safe. Do not wash the filter. Remove the filter before washing the bin.

## Cleaning the Filter

1 Remove the bin. Open bin door and remove filter.

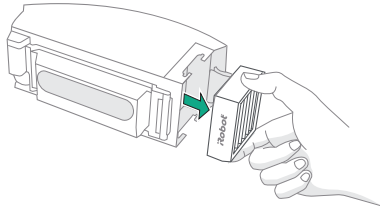

2 Remove debris with cleaning brush.

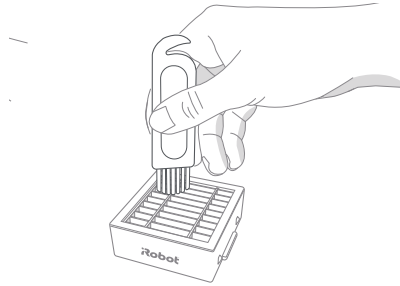

3 Empty and wipe the Bin with clean cloth.

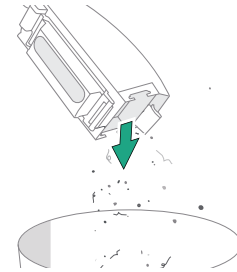

4 Reinsert filter. Place bin back in robot.

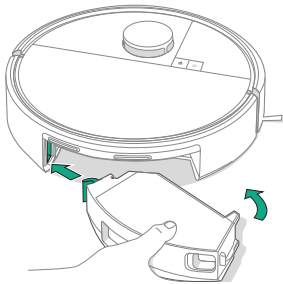

# Care and maintenance for your dock

To keep your dock running at optimal performance, perform the procedures on the following pages.

Part	Care Frequency	Replacement Frequency*
Charging contacts	Once every month	-
Sensors	Clean once a month	-
IR window	Clean once a month	-
Bags	-	Bags should be replaced when full - prompted by the LED indicator on the dock and/or Roomba® Home App
Dock filter	Once every month (remove debris from dock filter)	

\* Replacement frequency may vary. Parts should be replaced if visible wear appears. If you think you need a replacement part, please contact iRobot Customer Care for more information.

## Cleaning the Charging Contacts and IR Window

Inspect the components to make sure that they are clear of debris. Wipe with a clean, dry cloth.

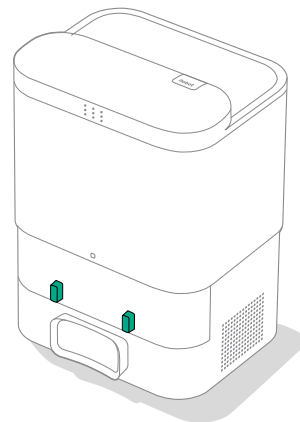

**IMPORTANT:** Do not spray cleaning solution or water onto the sensors or sensor openings.

## Replacing the Bag

- 1 Lift up on the canister lid to open.

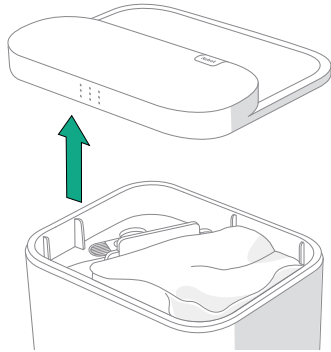

- 2 Pull up on the card to remove the bag from the canister.

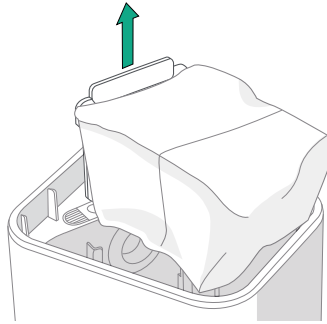

- 3 Install a new bag by sliding the card into the guide rails. This will seal the bag so dust and debris cannot escape.

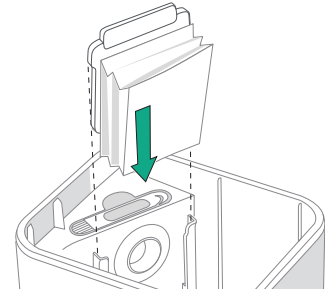

- 4 Press down on the lid making sure that it is completely closed.



**IMPORTANT:** To achieve optimal performance with your robot and dock, clean and/or replace your robot's filter as needed.

## Removing Debris from Dock Filter

Inspect blower cover for any lint or debris build-up, and wipe with a clean dry cloth to remove.

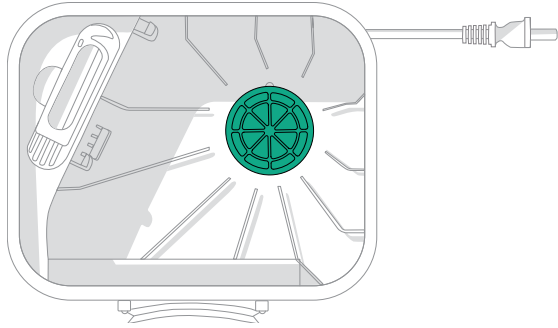



# Troubleshooting

## Troubleshooting your robot

Your robot will alert you if something is wrong with a voice announcement or audio alert. The Roomba® Home App will also provide notifications with steps to troubleshoot any issues.

If you are unsure if the robot is finished or paused, consult the Roomba® Home app to check on its status.

## Factory Reset

To factory reset press  for 5 seconds and then (within 5 seconds) press  +  for 5 seconds.

## BATTERY SAFETY & SHIPPING



**WARNING:** Lithium ion batteries and products that contain lithium ion batteries are subject to stringent transportation regulations. If you need to ship this product for service, travel or any other reason, you **MUST** follow the below shipping instructions.

- Battery **MUST** be turned off before shipping.
- Turn off the battery by removing the robot from the dock and press the bumper in for 10 seconds while holding the  button. All indicators will then turn off.
- Package the robot securely for shipping.

If you need further assistance, please visit your Roomba® Home app, contact our Customer Care team or visit [global.irobot.com](https://global.irobot.com).

## Troubleshooting your dock

Your dock will tell you if something is wrong via an LED indicator on the front of the canister and through the Roomba® Home App. If the dock is not performing as expected, check the Roomba® Home app for errors.

LED indicator	Common error	How to fix
Solid red	Bag full or missing	Replace bag if it is full or missing. Make sure that the bag is securely inserted. If problem persists, remove any debris from the port on the bottom of your robot and dock.

This product has been equipped with a thermal protector designed to protect against damage due to overheating. If the protector operates, the motor will stop running. If this happens, unplug the unit, allow it to cool for 30 minutes, clear any obstructions from the evacuation port and evacuation tube, then plug the unit back in.



## Need further assistance? We're here to help.

Download the Roomba® Home App or visit [global.irobot.com](https://global.irobot.com) for product support or to contact your local support center. If you need further assistance in the US & Canada, call the US Customer Care team at (877) 855-8593.

### **iRobot USA Customer Care Hours**

Monday to Friday, 9AM — 9PM Eastern Time

Saturday and Sunday 9AM — 6PM Eastern Time

## Safety Information

Please see the safety guide that came with your robot, or visit [global.irobot.com](https://global.irobot.com)



WC# 4851434 vA



©2025 iRobot Corporation, 8 Crosby Drive, Bedford, MA 01730 USA. All rights reserved. iRobot, Roomba, and Roomba Combo are registered trademarks of iRobot Corporation. AutoEmpty and AutoWash are trademarks of iRobot Corporation. Wi-Fi and the Wi-Fi logo are registered trademarks of Wi-Fi Alliance. Apple and App Store are trademarks of Apple Inc., registered in the U.S. and other countries. Google Play is a trademark of Google LLC.