

witt

HEAT 80 R

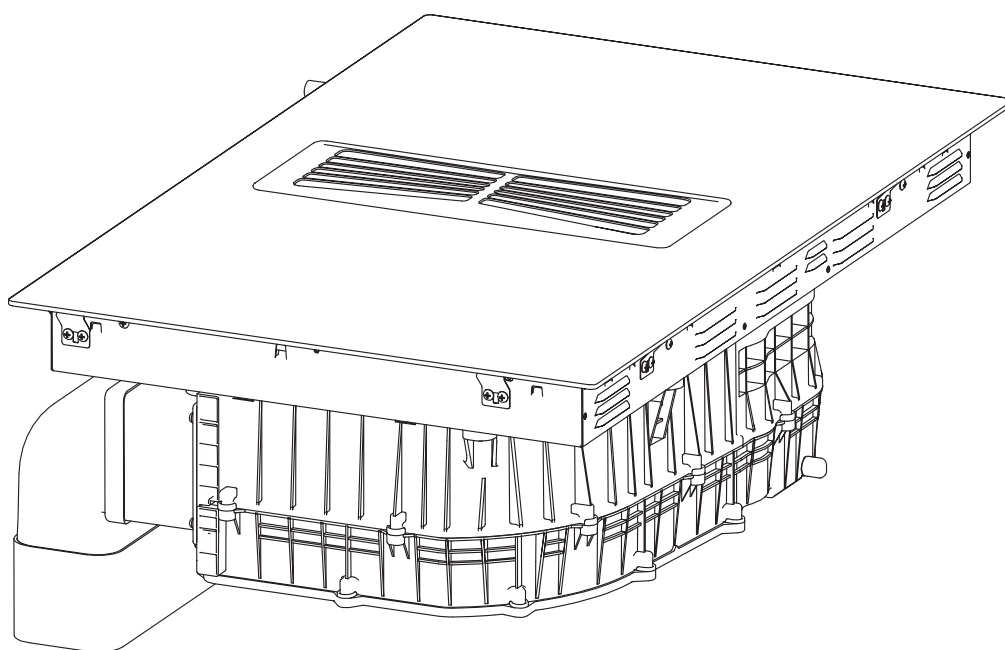

ILLUSTRATIONS / INSTALLING THE PRODUCT

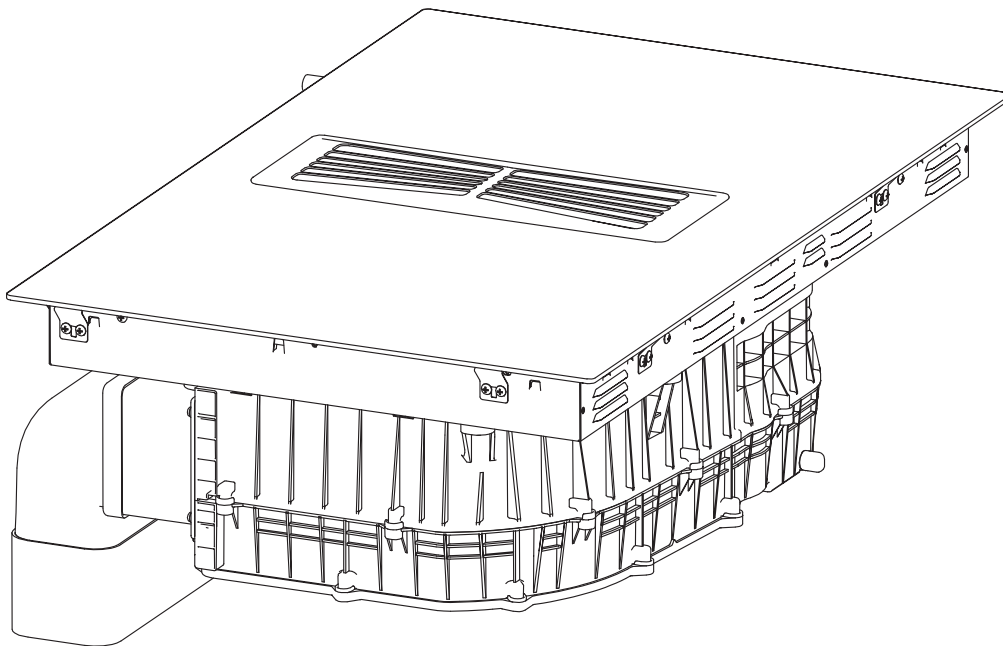



1×,A



1×,B



7×M5



3 ×

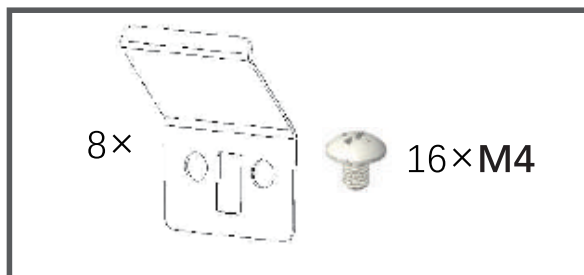

1×

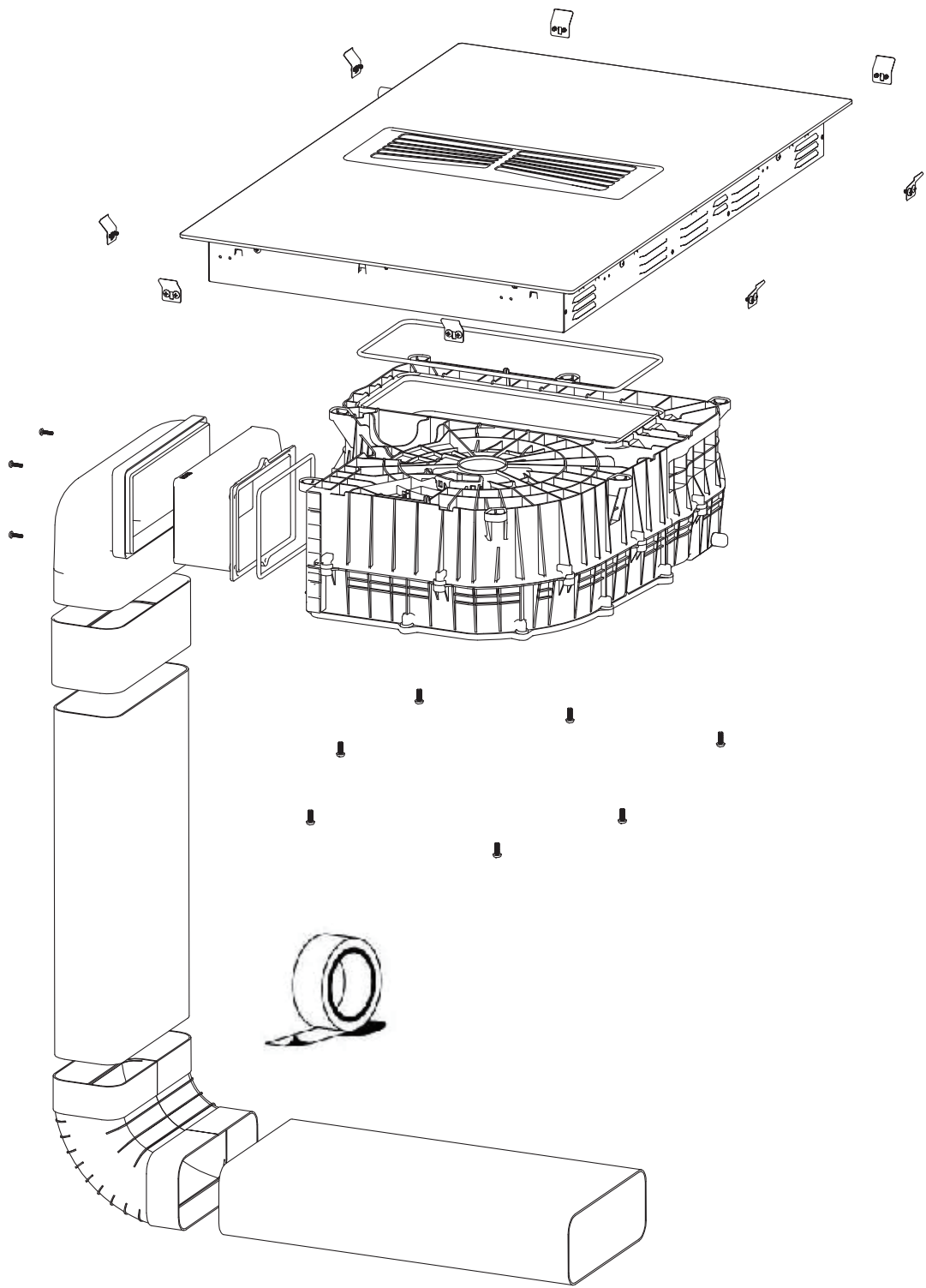

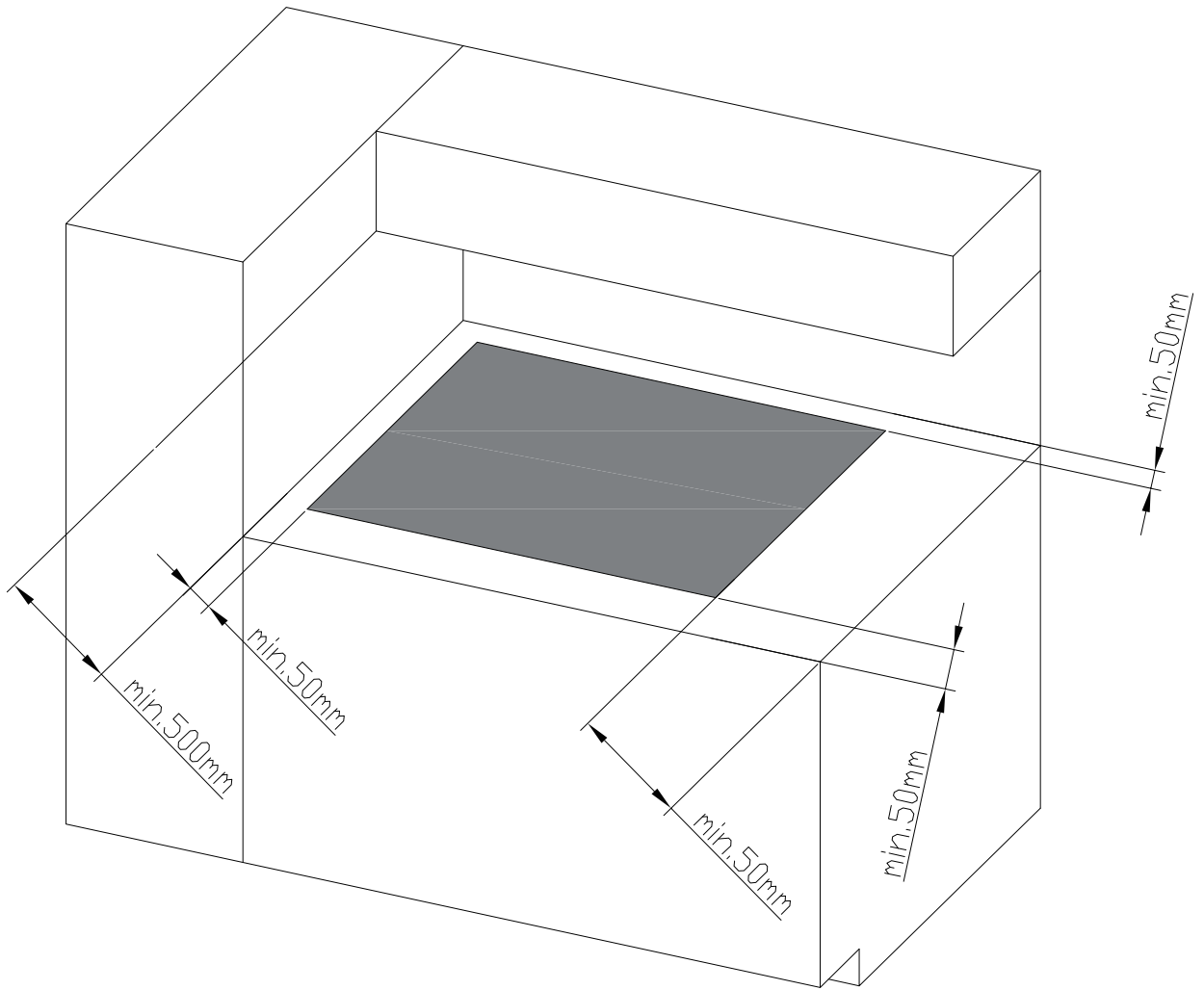

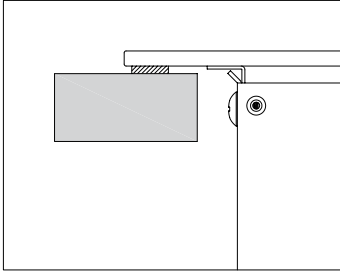

Inst.A
Flush mounting

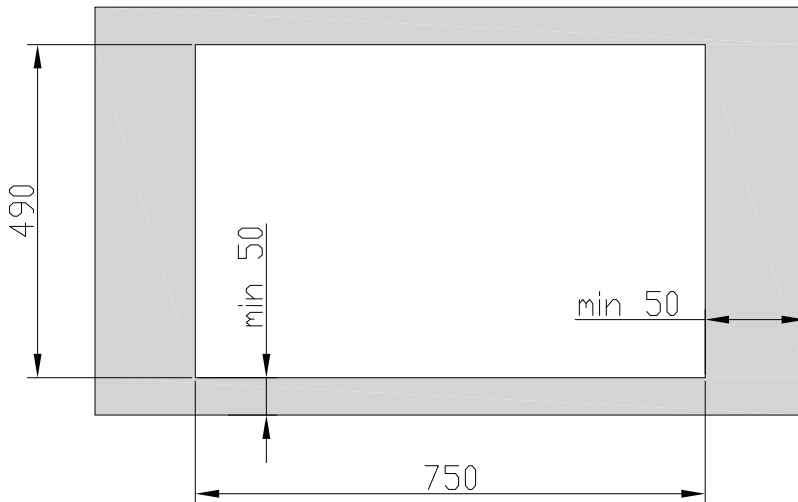
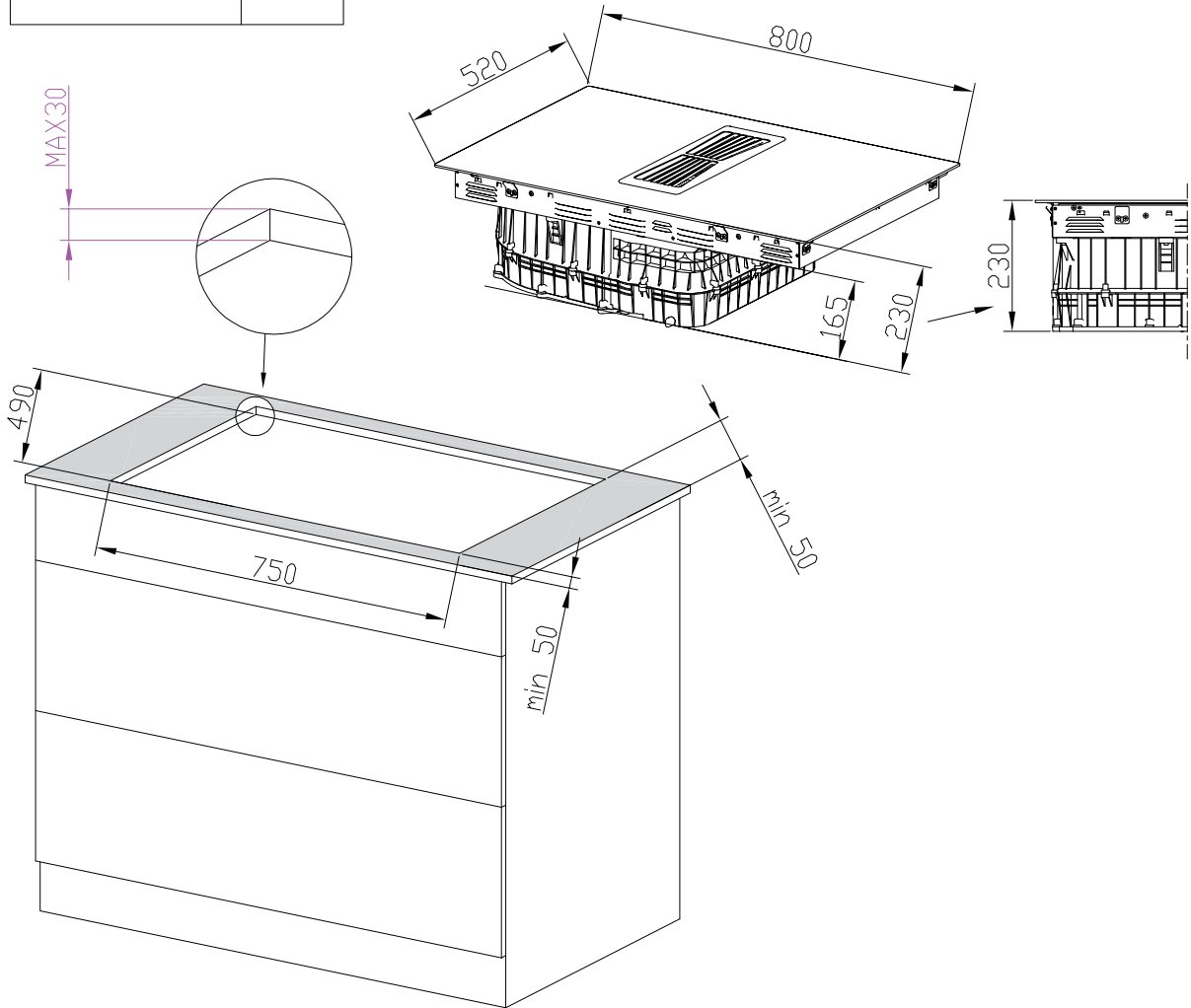

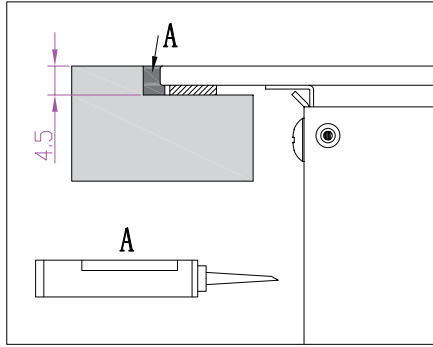

Inst.B
Level with worktop

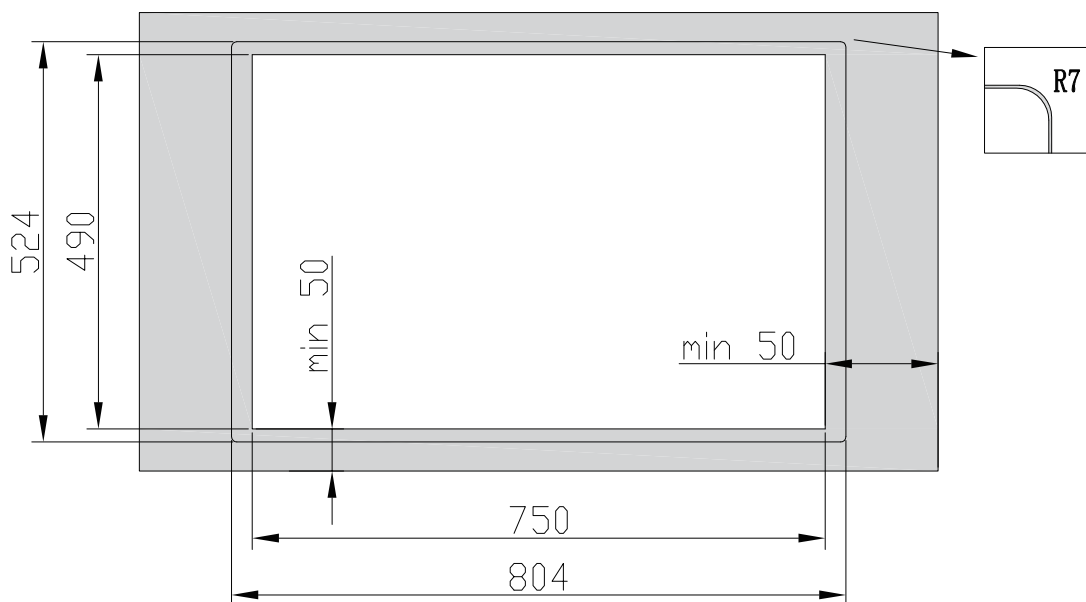
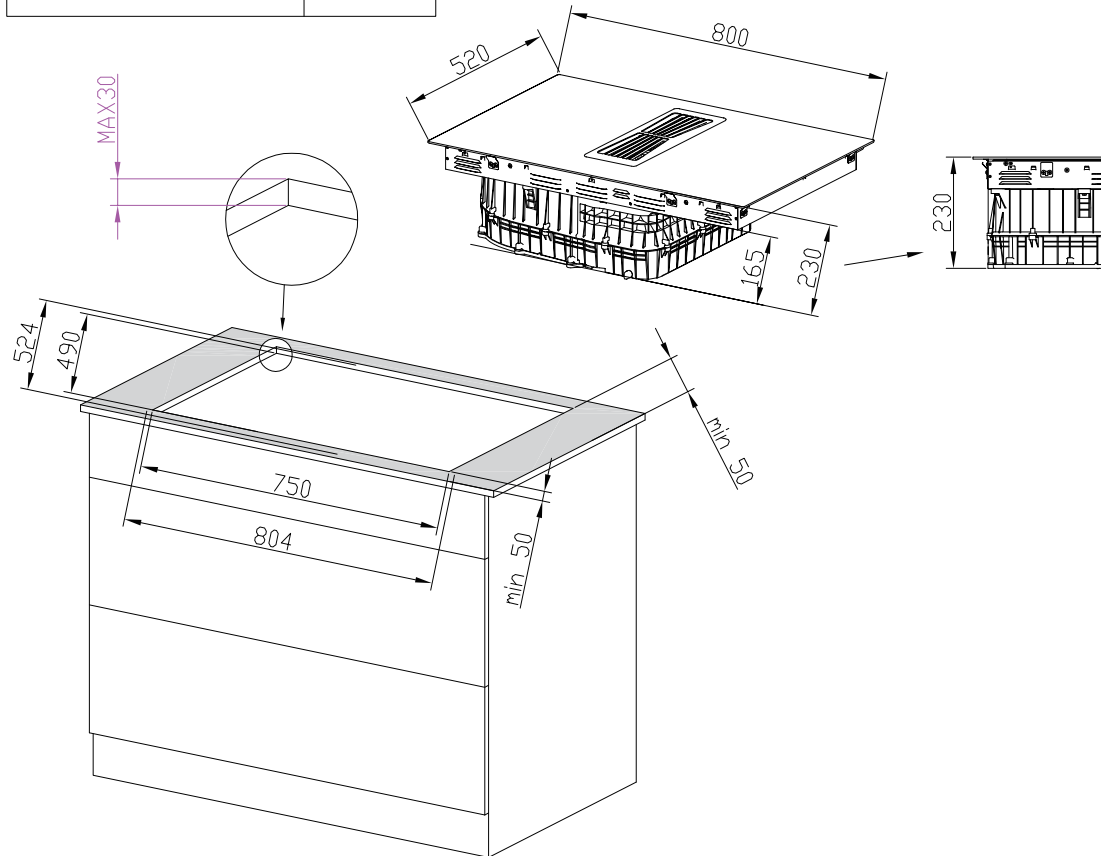

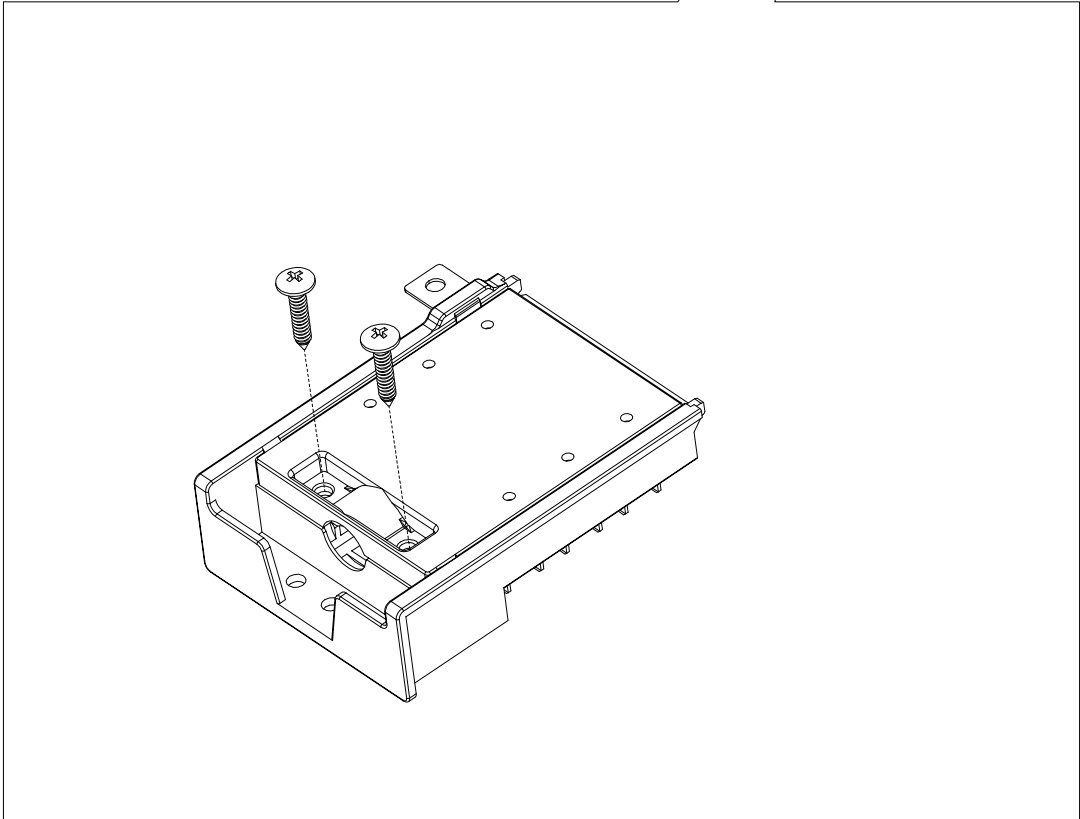
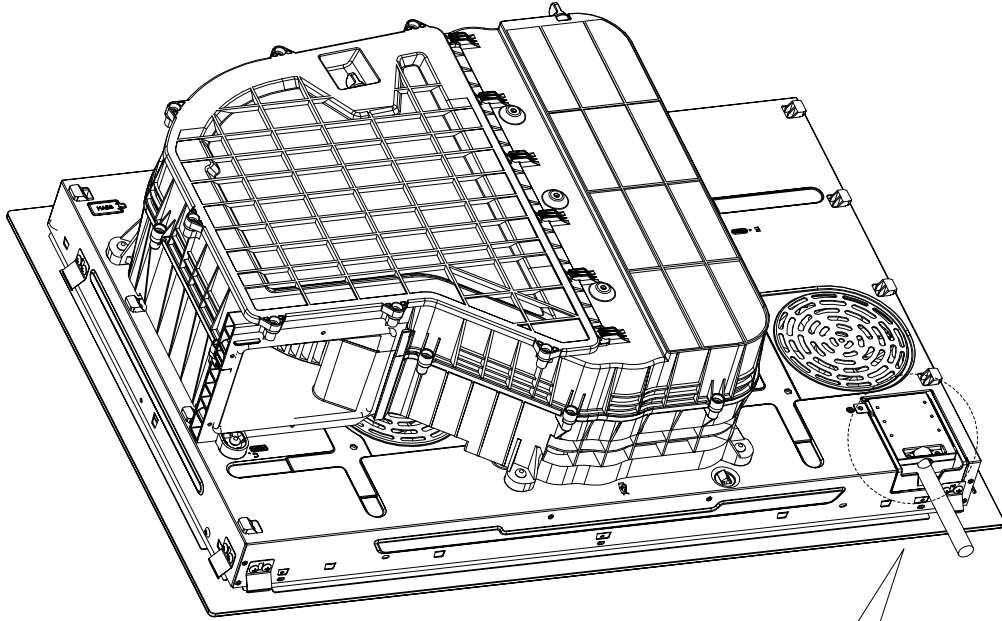

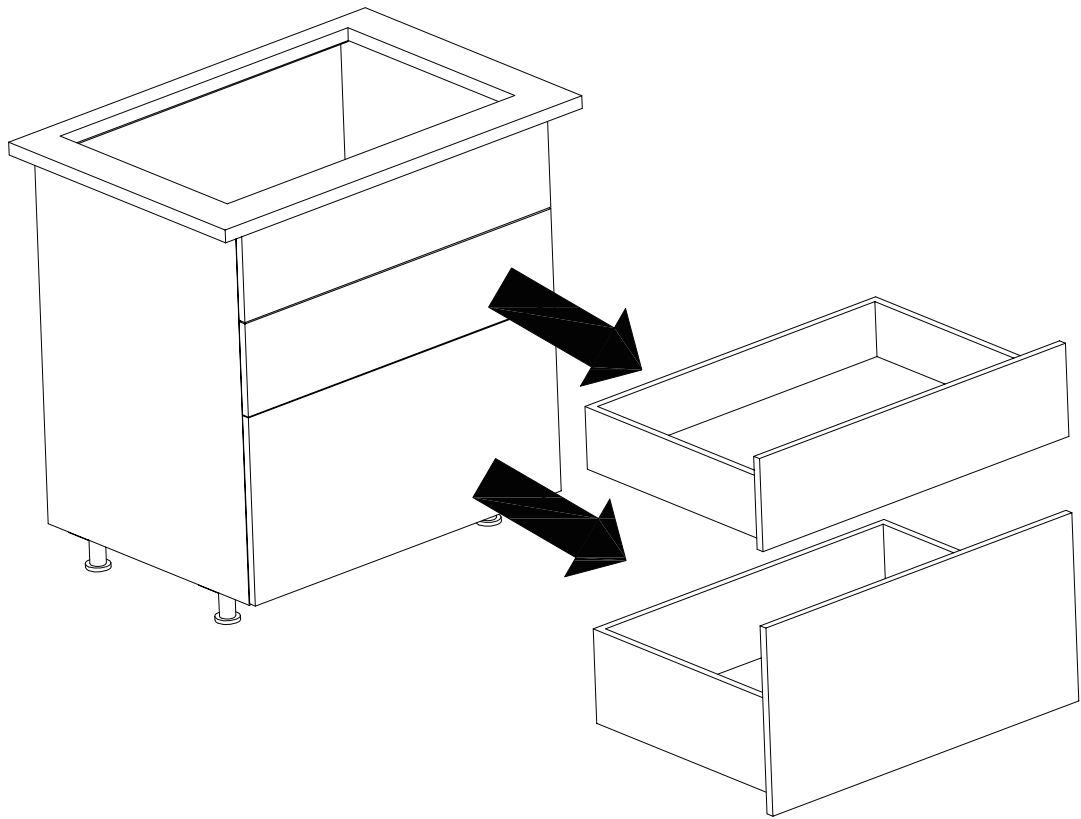

OK!

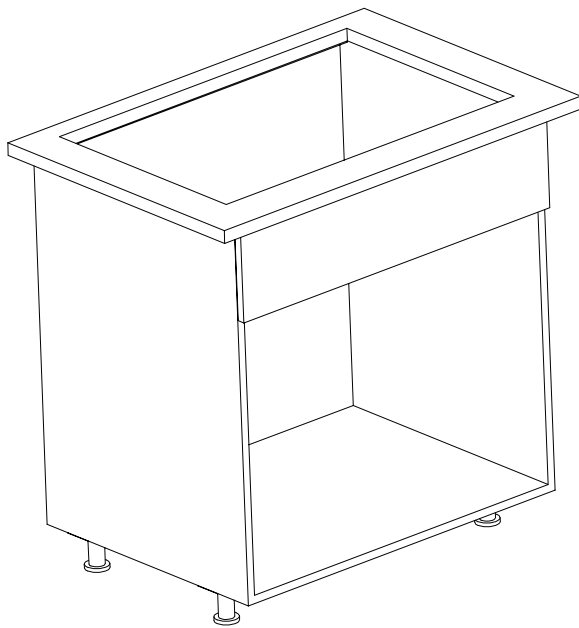

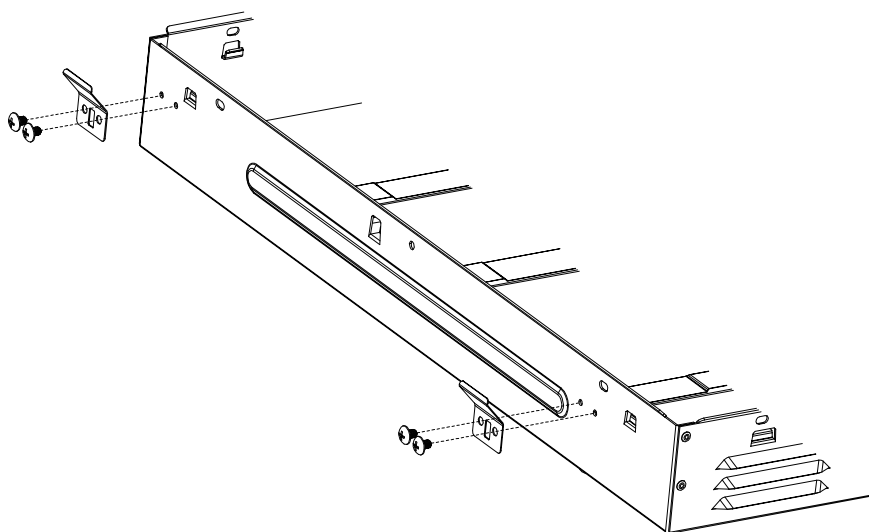
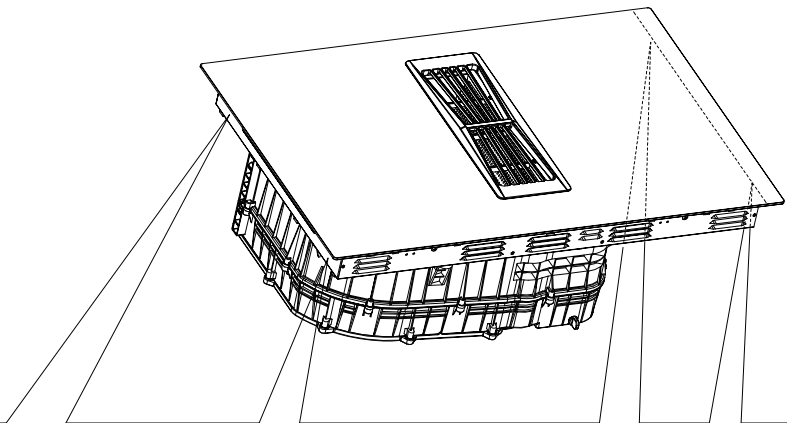

OK!

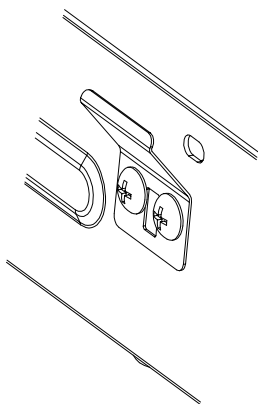

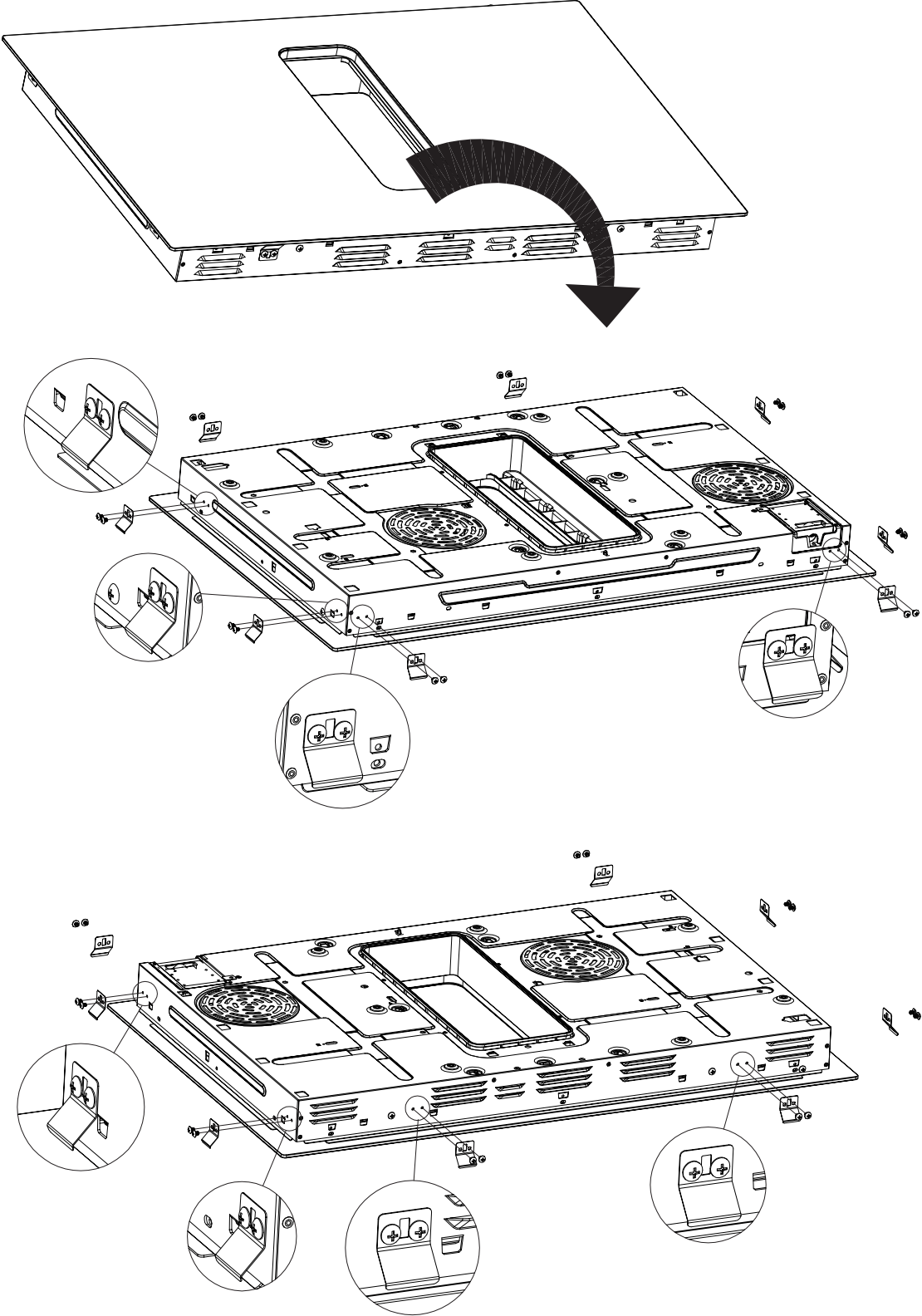
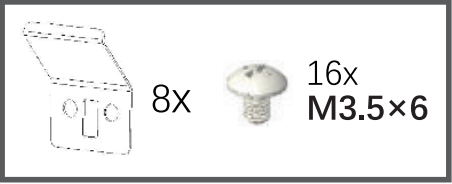

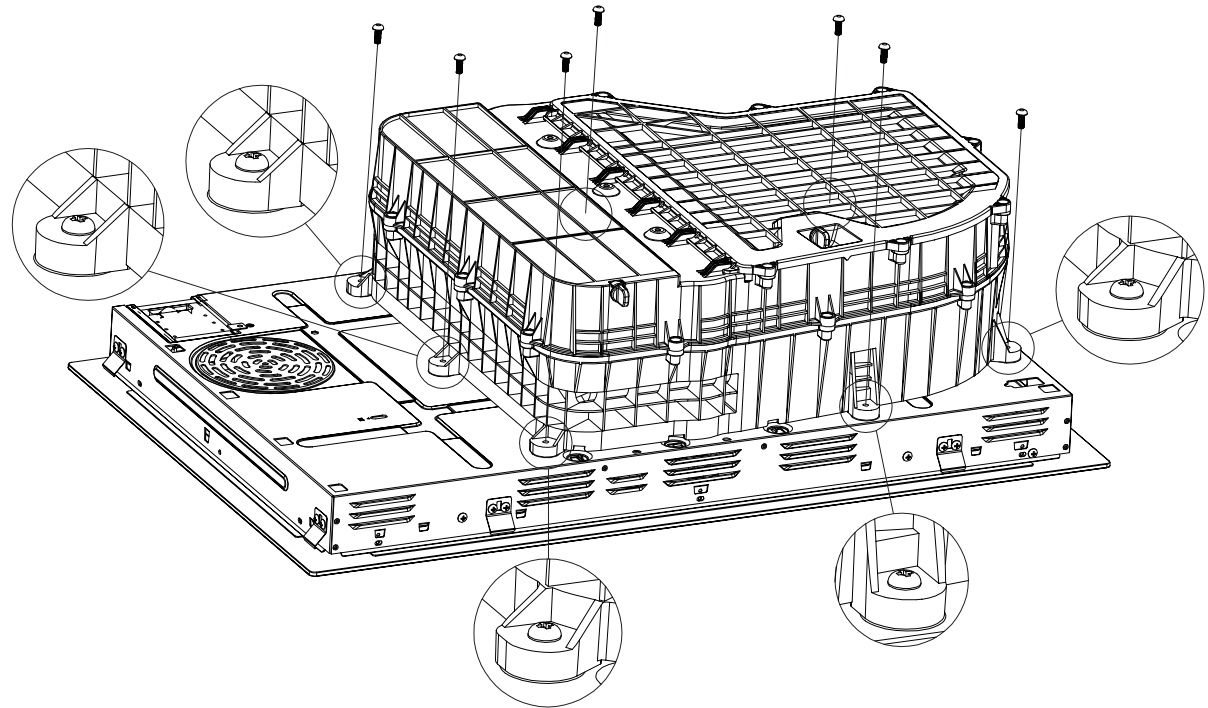
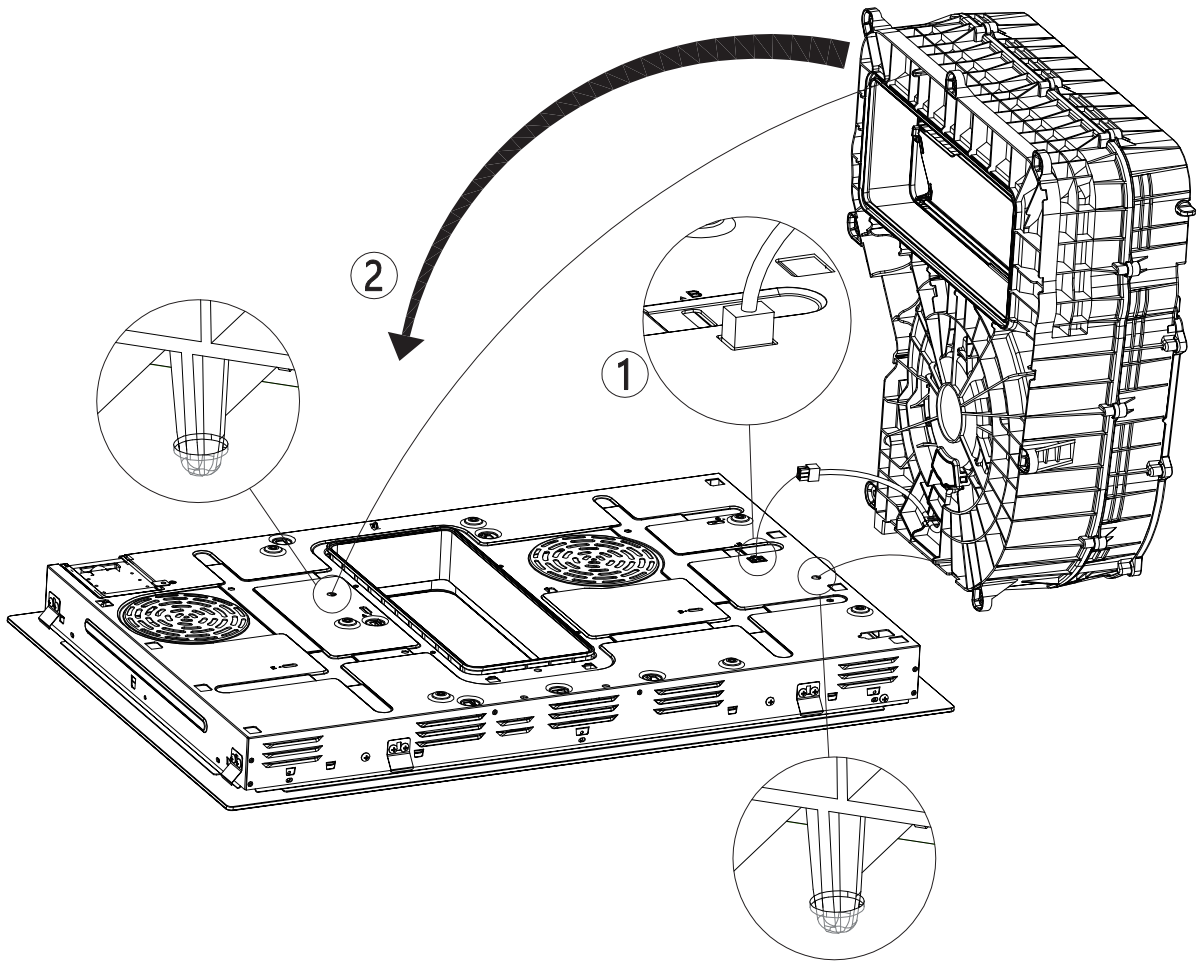

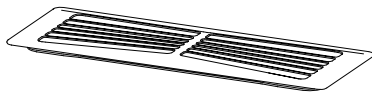
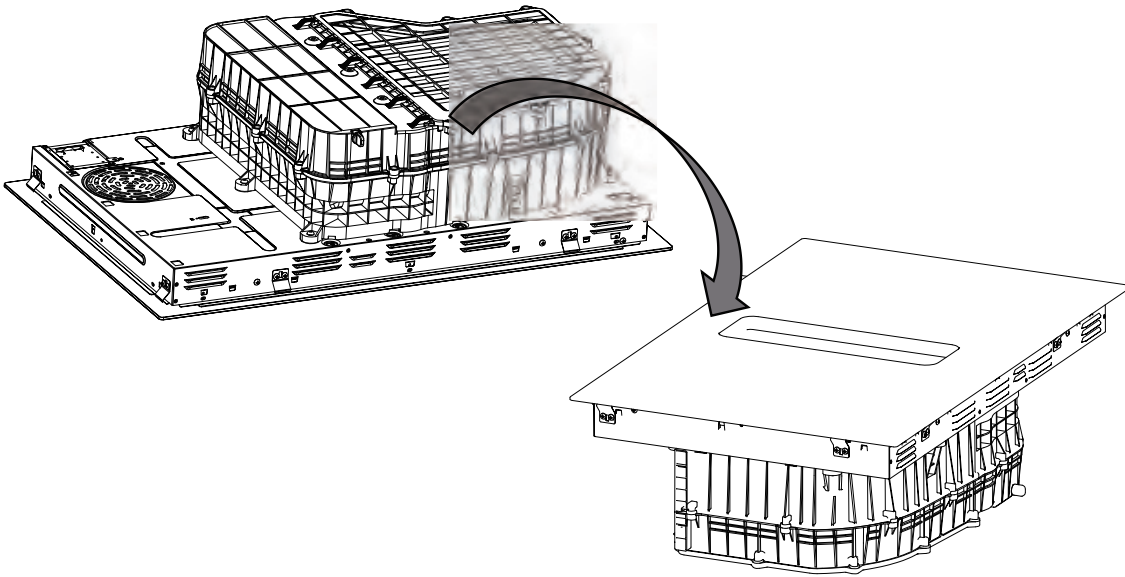

1x

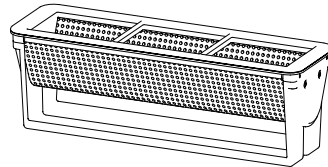

1x

②

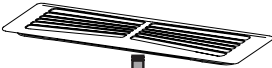

①

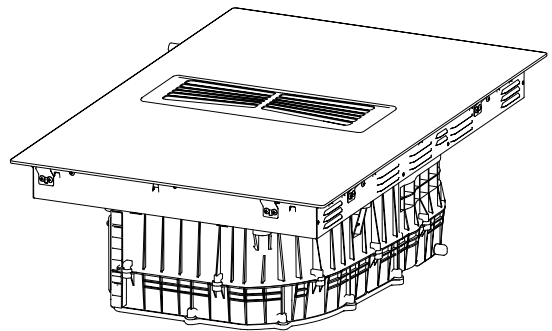
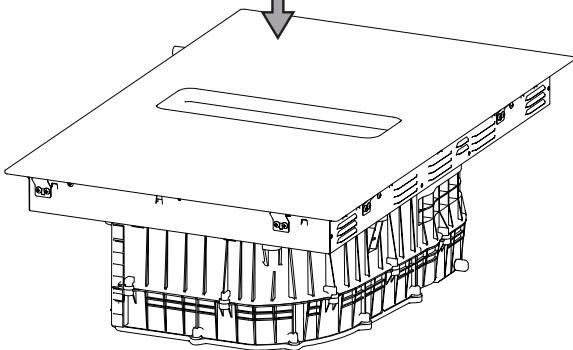
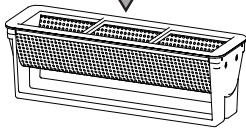

OK!

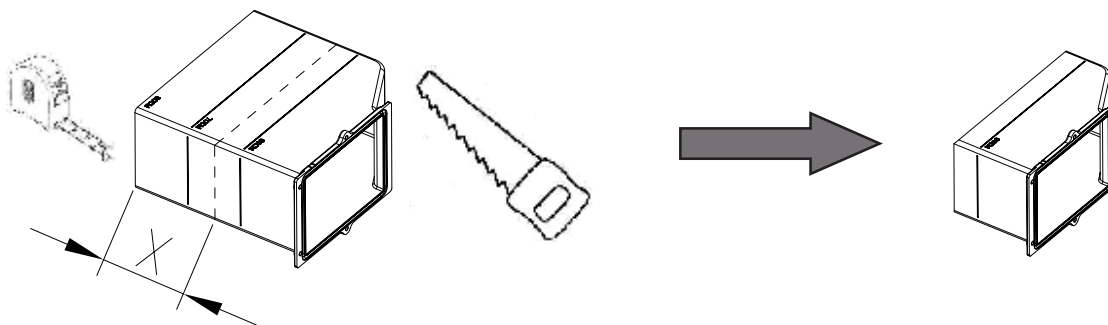
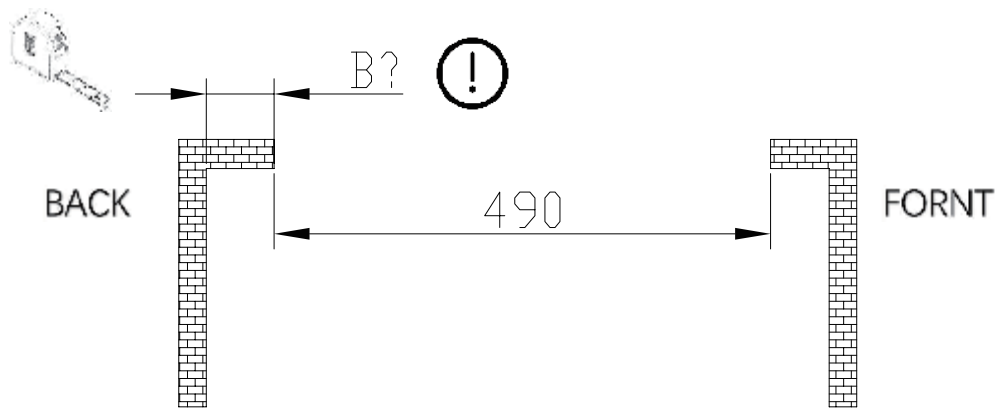
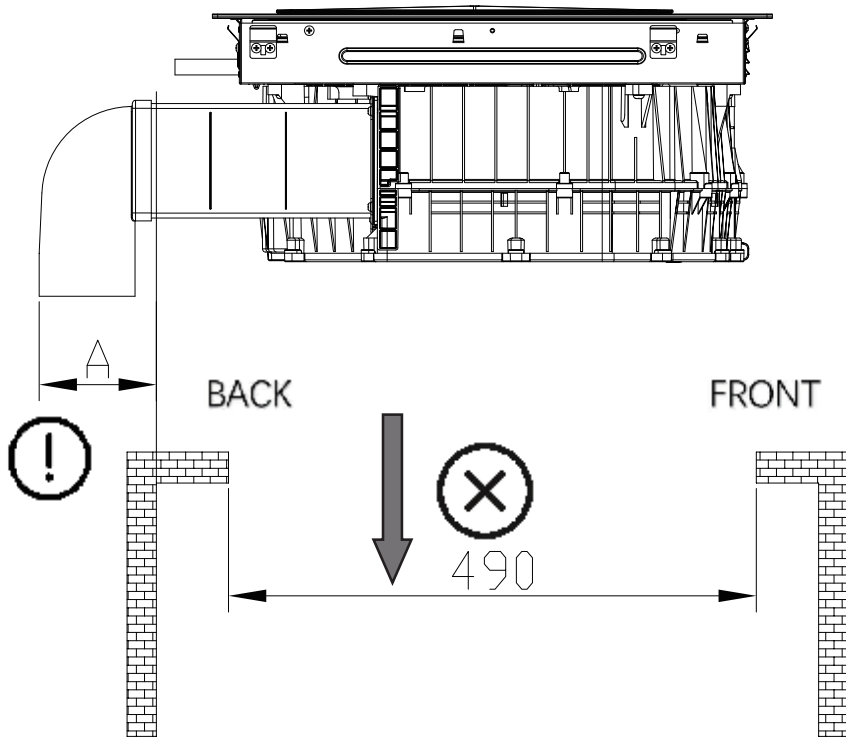

X=186-B

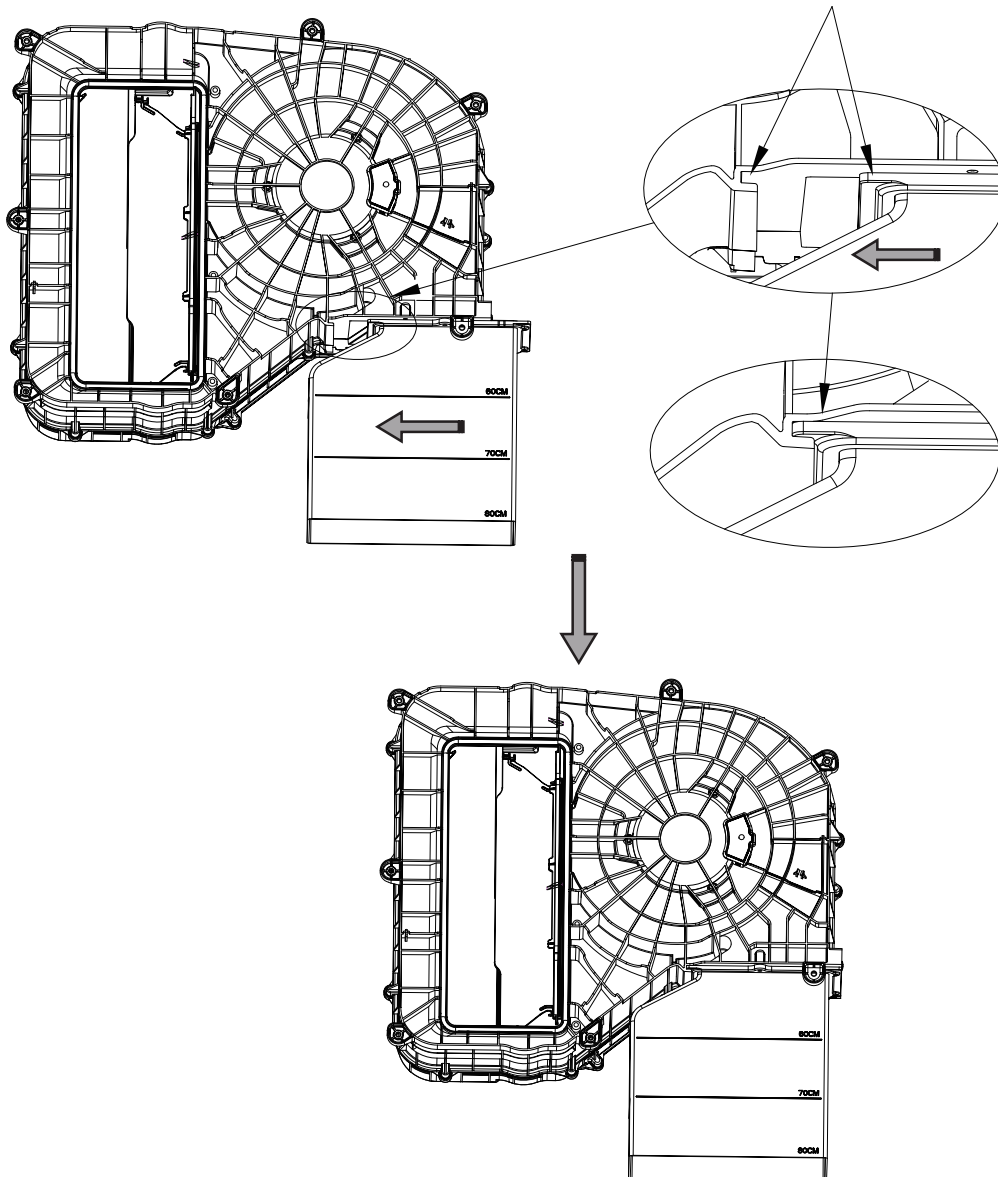
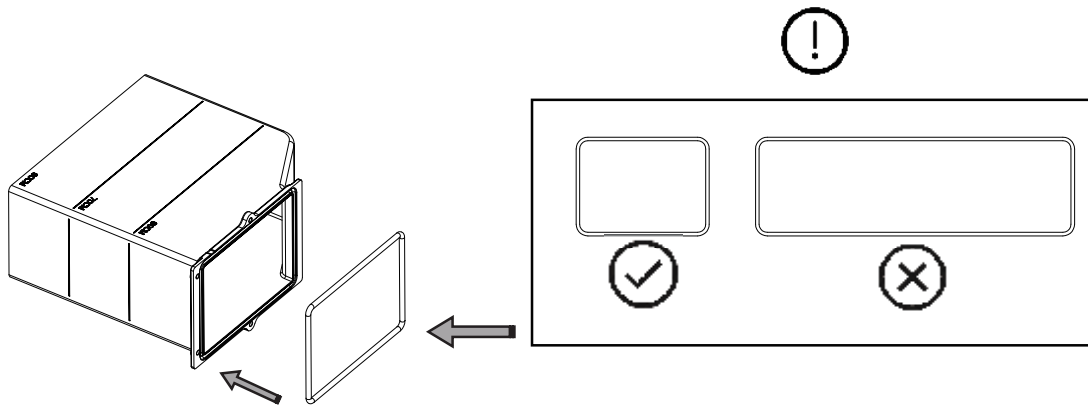

3x
ST3.5×14

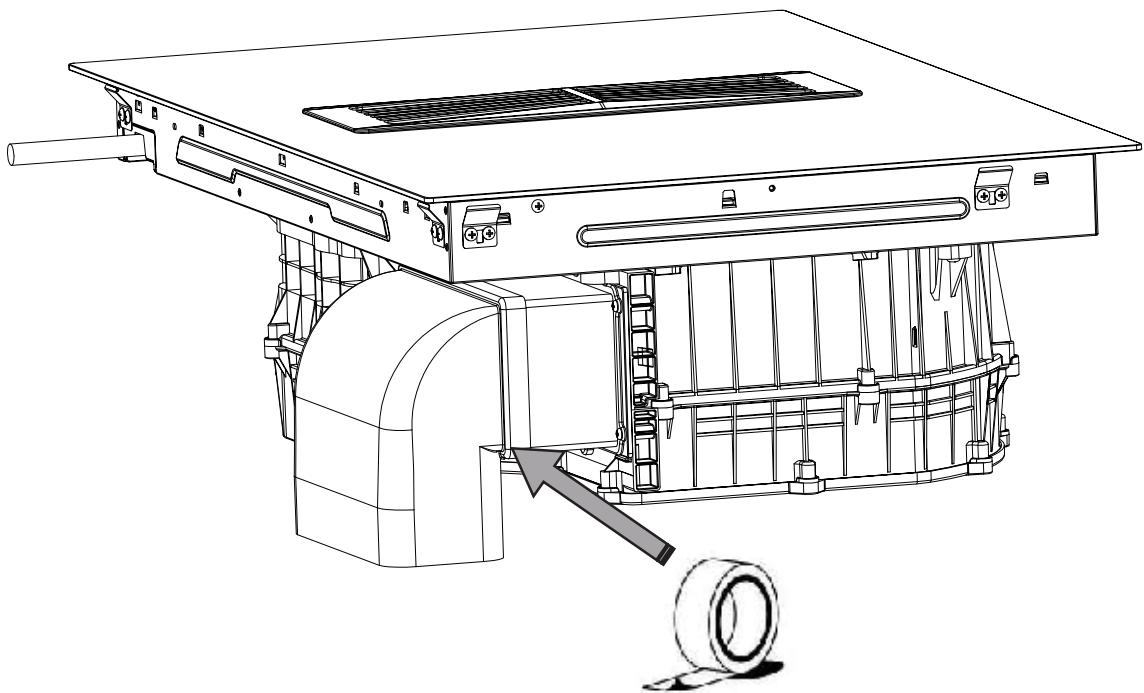
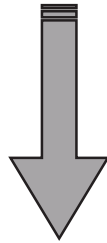
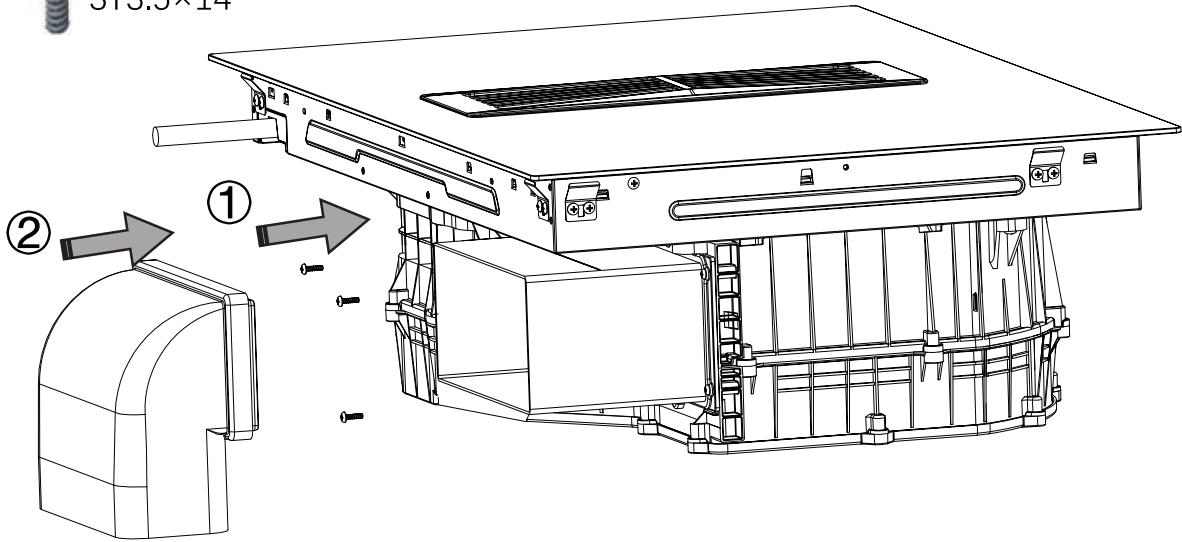

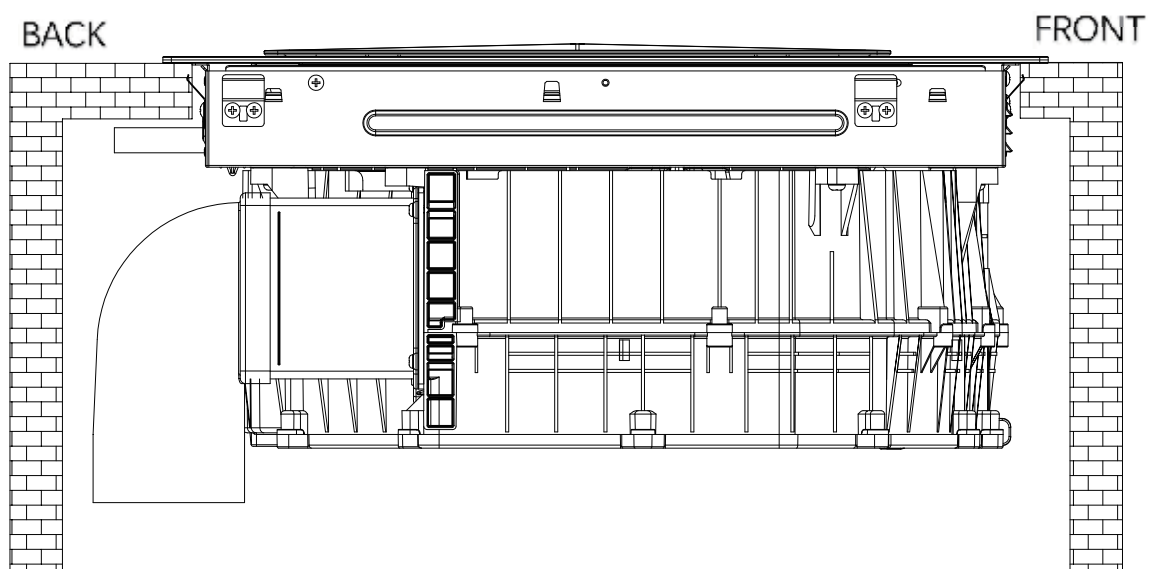
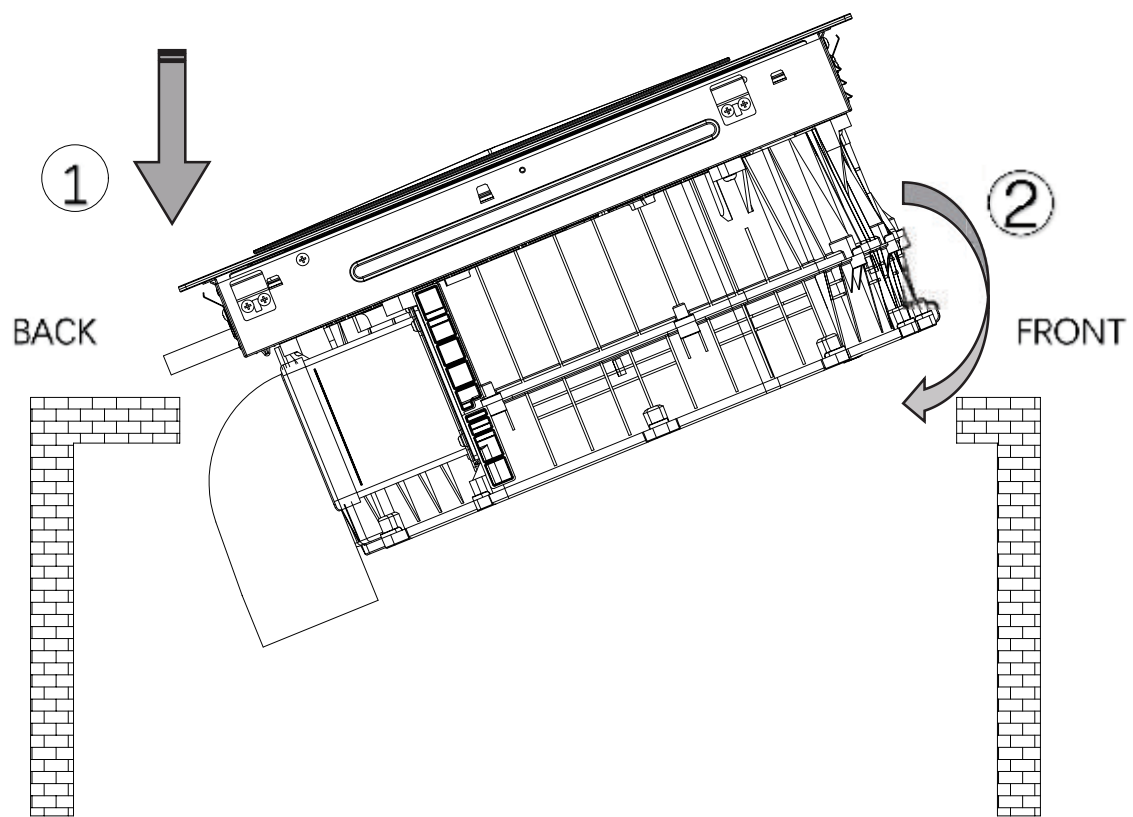

OK!

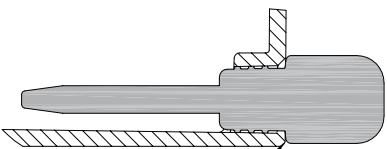
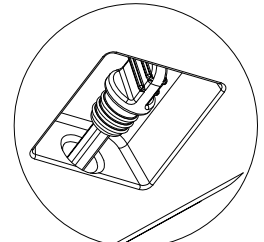
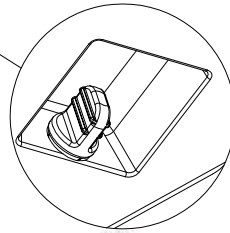
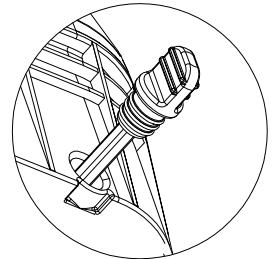
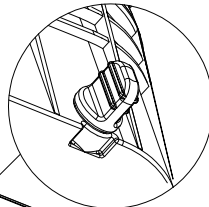
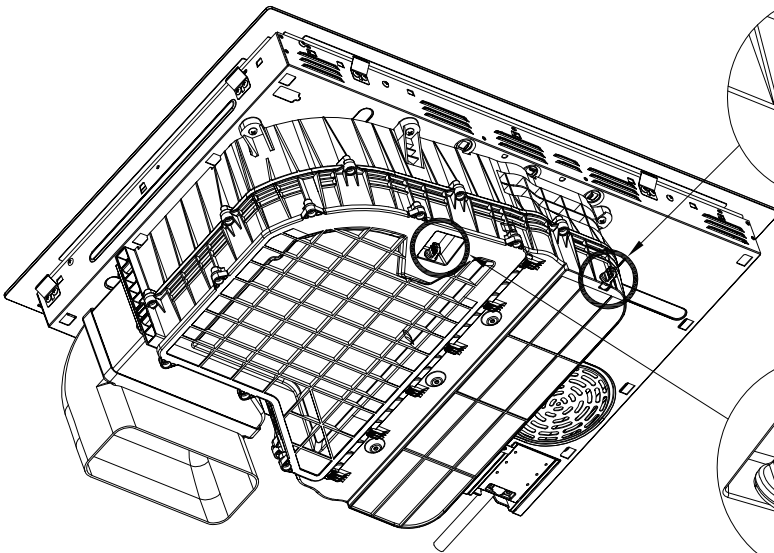

OK!

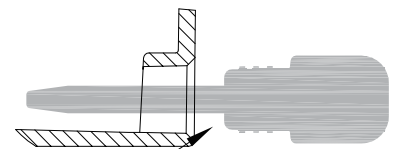
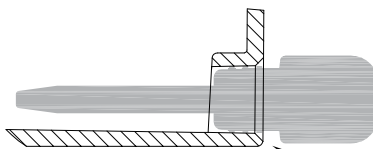

NG!

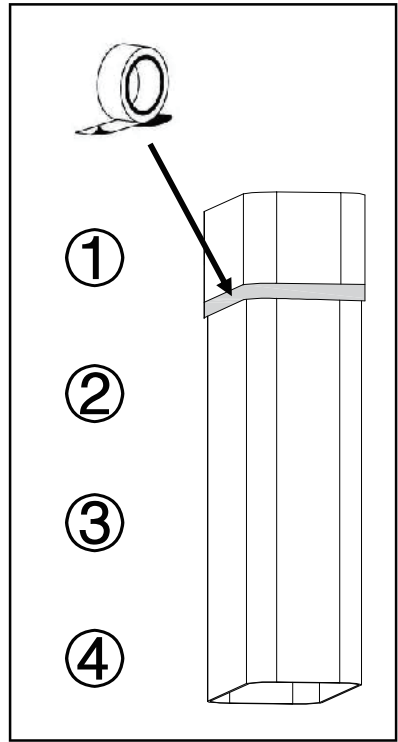
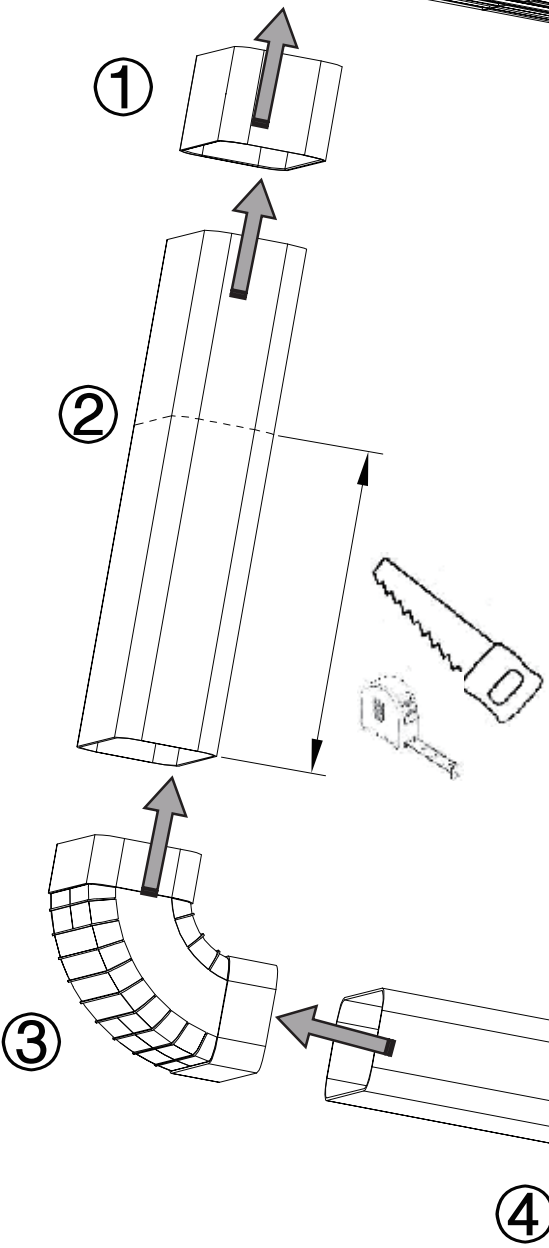
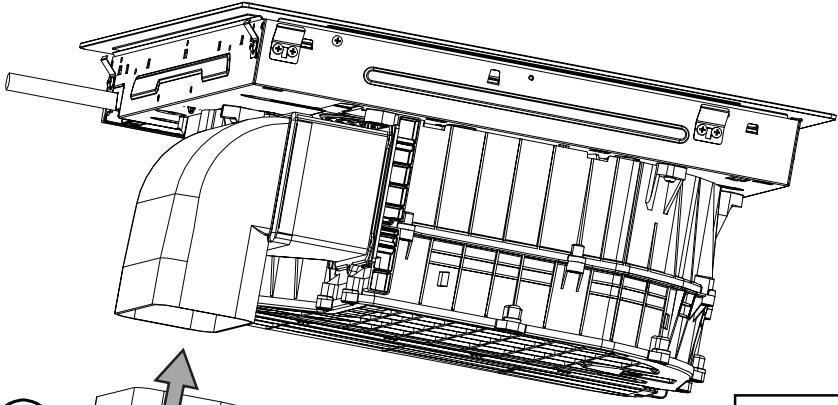

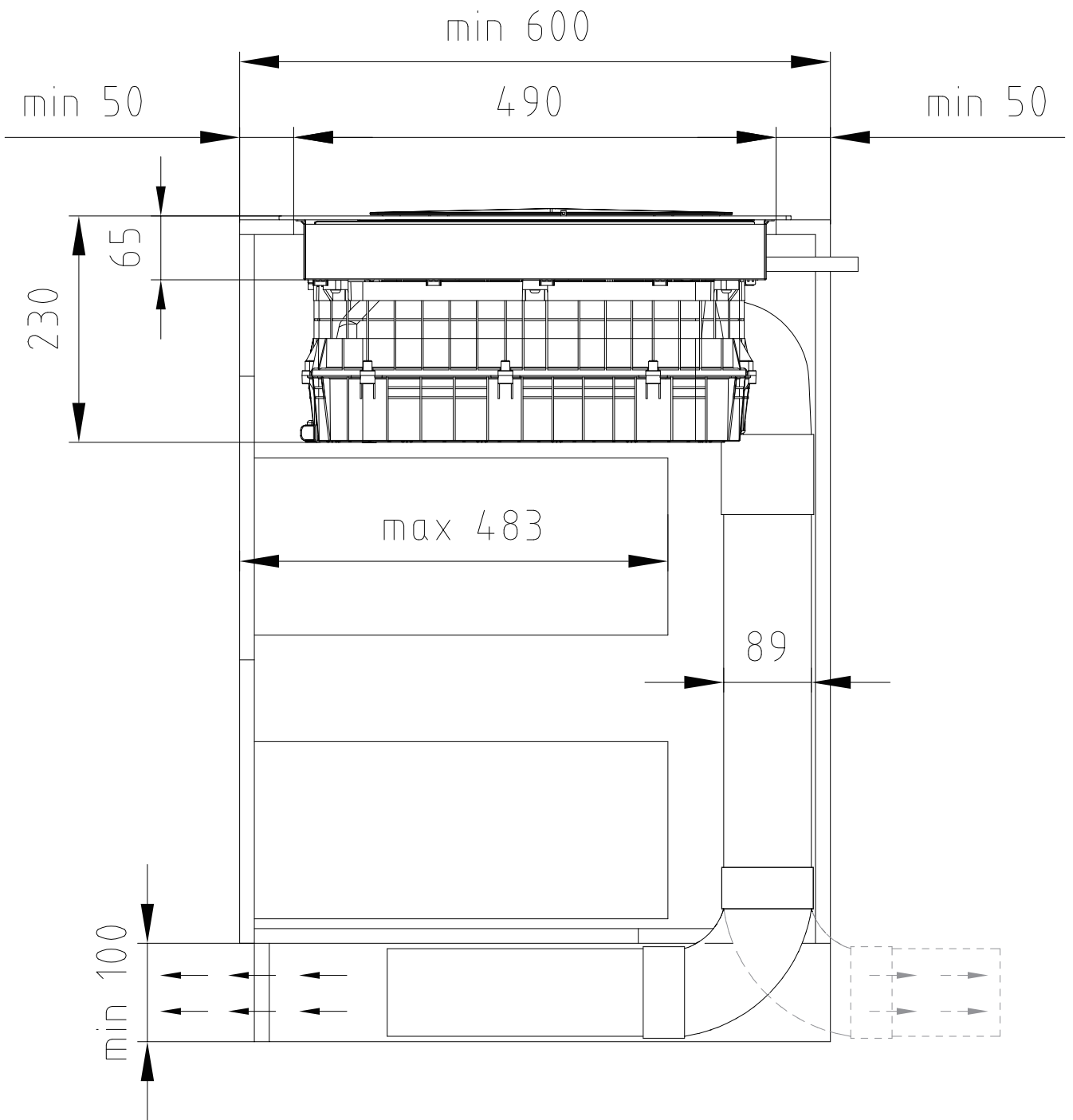

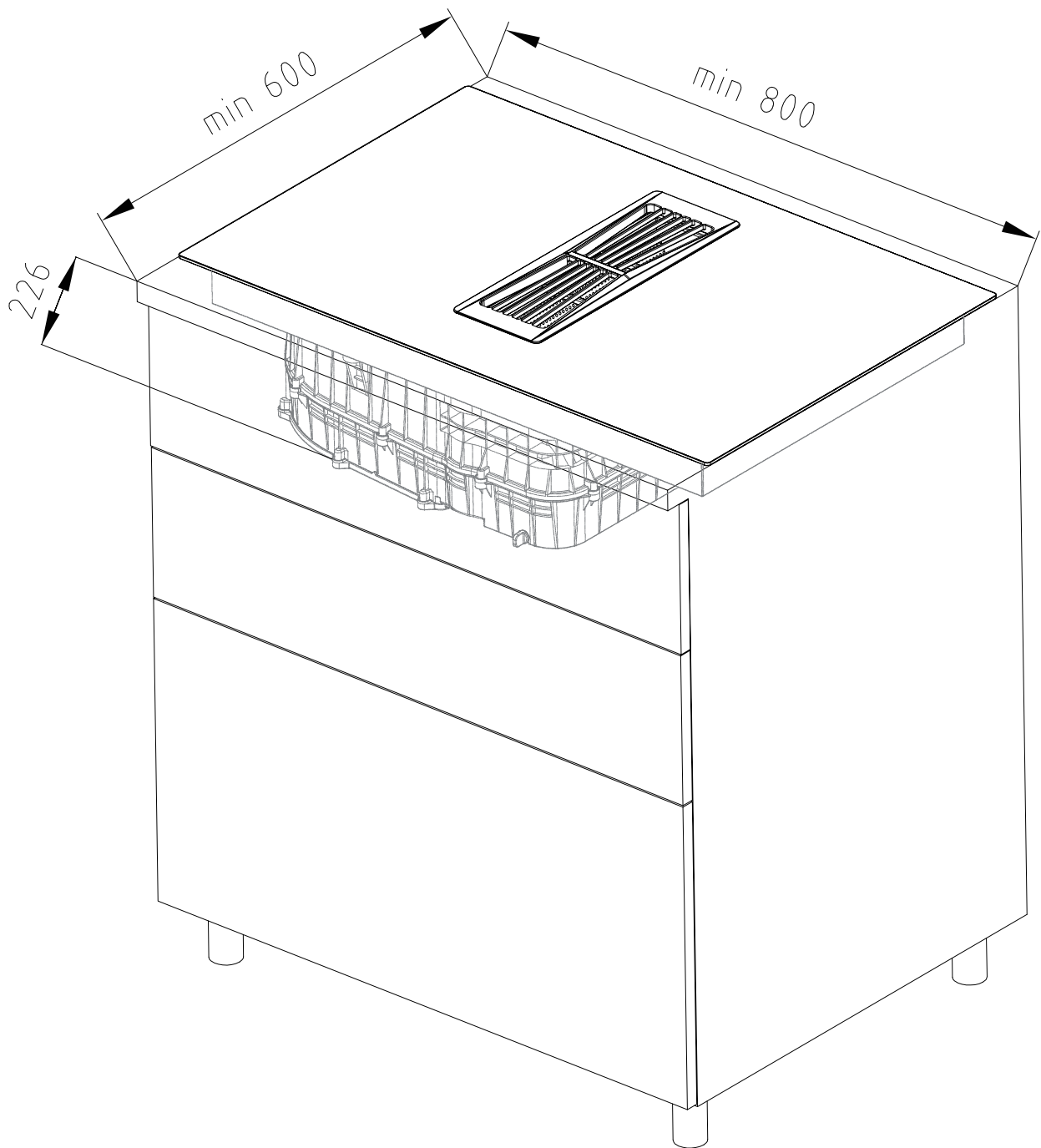

OK!

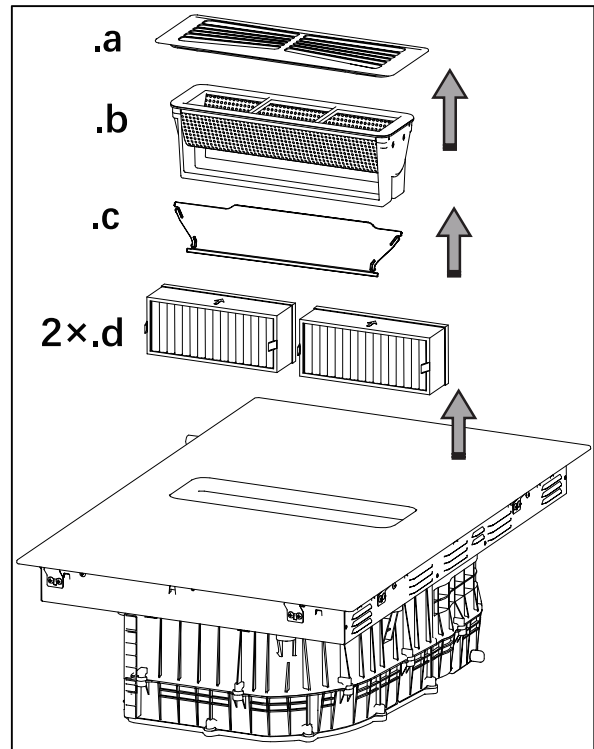
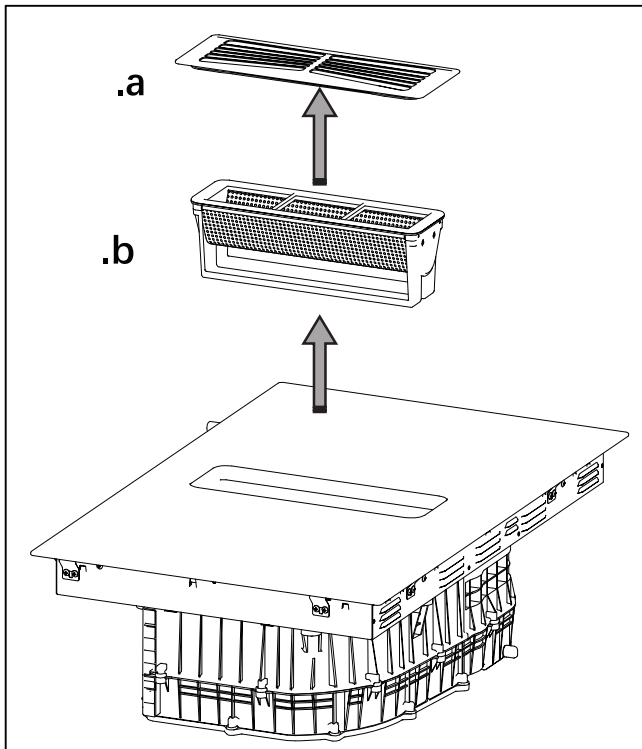
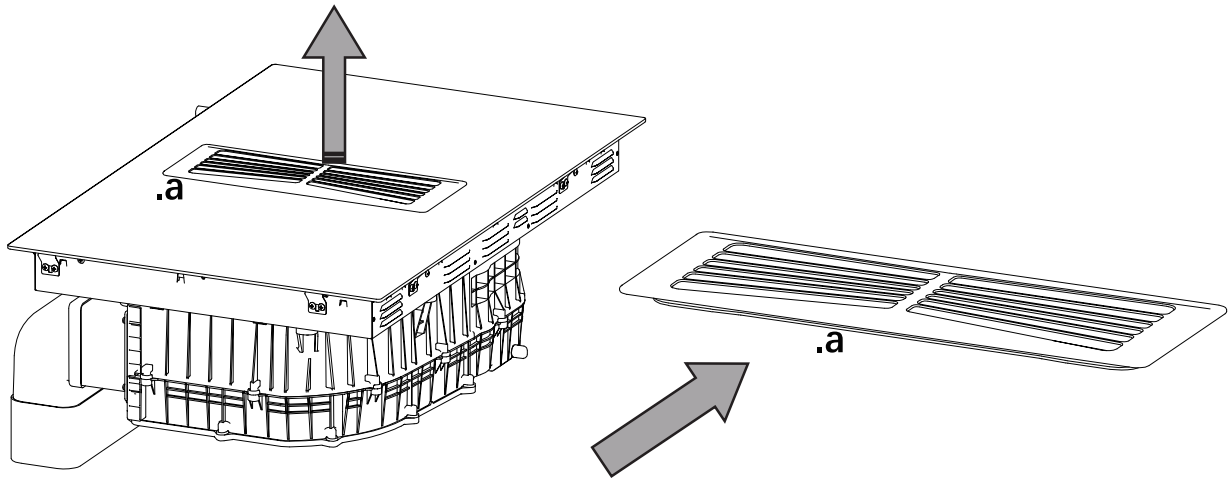



This side faces up,
open it here when cleaning.

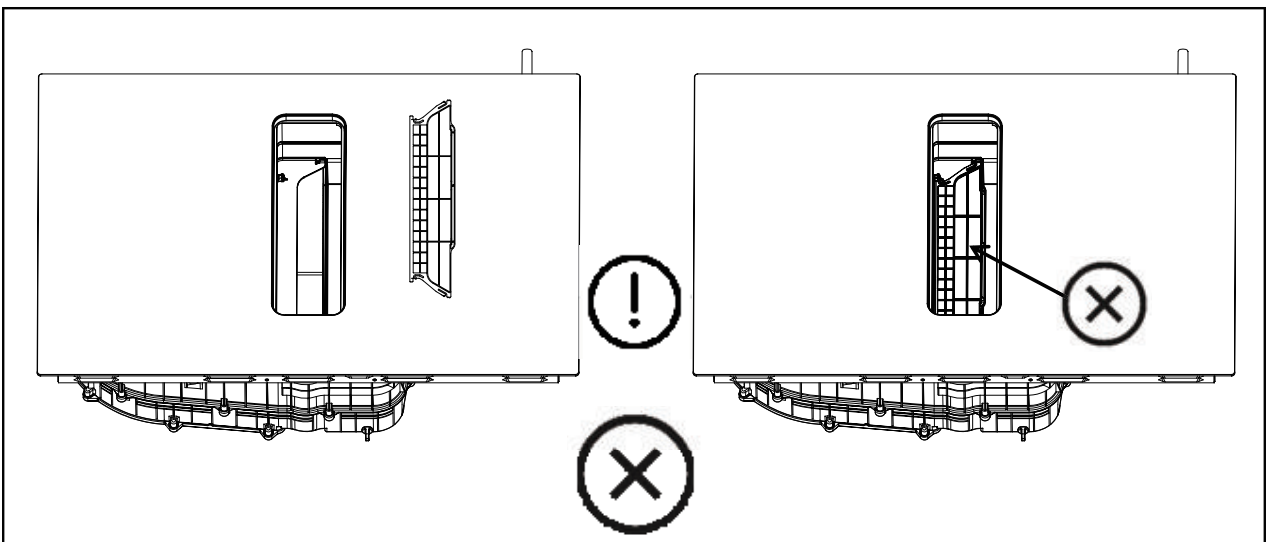
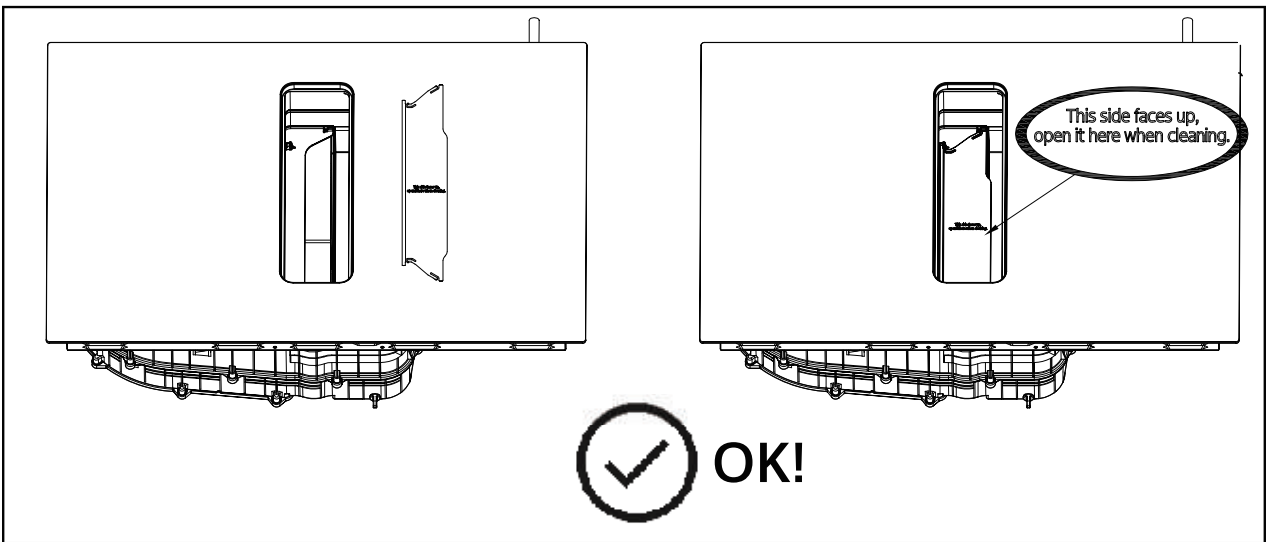
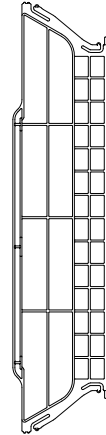

CONGRATULATIONS on your new Witt product

Thank you for choosing Witt. Before using your new product, please read these instructions carefully to ensure that you know how to safely use the functions provided by your new product.

TABLE OF CONTENTS

ILLUSTRATIONS	2
SAFETY INSTRUCTIONS	26
SPECIFICATIONS	31
OVERVIEW OF YOUR PRODUCT	32
QUICK GUIDE	35
OPERATING INSTRUCTIONS	41
CLEANING AND MAINTENANCE.....	48
TROUBLESHOOTING	52
WARRANTY AND SERVICE	58

SAFETY INSTRUCTIONS

The following safety guidelines are intended to prevent unforeseen risks or damage from unsafe or wrong operation of the device. Please inspect the device and packaging when receiving it to ensure that everything is intact and that it is safe to operate. If you find damage, please contact the dealer you bought it from.

Please note that for your own safety it is not permitted to make changes to the device. Unwarranted use may result in danger and the loss of warranty.

Please read these instructions carefully before using/starting the device and store these instructions close to the place of installation or the device for later use.

Safety warnings

Your safety is important to us. Please read these instructions before using your hob plate. Please follow the instructions in this manual carefully. There is no liability for any problems, damage or fires caused by failures to comply with the instructions in this manual. The device is only intended for household use, cooking and the absorption of fumes generated while cooking.

No other uses are permitted (such as, for example, using it to heat a room). The manufacturer accepts no liability from unwarranted use or incorrect settings.

The product may have different aesthetic expressions compared to the illustrations in these instructions, but the operating, maintenance and installation instructions will remain the same.

Installation

- Disconnect the device from the power supply before carrying out any work or maintenance on it.
- It is critical and mandatory to attach the device to a good grounding system.
- Changes to the wiring system may only be carried out by a qualified electrician.
- Failure to comply with this recommendation may result in electric shock or death.
- Installation and maintenance work must be carried out by qualified technicians in accordance with the manufacturer's instructions and local safety provisions. Do not repair or replace any part of the device unless this is specifically stated in the operating instructions.
- It is mandatory to ground the device.
- The power cord must be long enough to allow for the attachment of the device to the electrical network.
- To ensure that the installation complies with relevant safety standards, it is required to use a regular omnipolar switch that ensures a complete decoupling from the power supply under category III overvoltage conditions in accordance with the installation rules.
- Do not use multiple sockets or extension cords. When the installation is completed, the electrical components must be inaccessible to the user.
- Before the device is attached to the electric network: Make sure that the connections are in accordance with the connection data (voltage and frequency) specified on the type plate. It is very important that this data matches so that the hood is not damaged. When in doubt, contact a professional.

Please take care to avoid cuts!

- Be careful - the edges of the panels are sharp.
- If you are not careful, you may get an injury or a cut.

Important safety instructions

- Read these instructions carefully before installing or using this device.
- No flammable materials/products should ever be placed on this device.
- Please provide these instructions to the person responsible for installing the device as it may reduce your installation costs.
- To avoid danger, this device should be installed in accordance with these installation instructions.
- This device must only be installed and grounded by a person with suitable qualifications.
- This device should be connected to a circuit that contains an insulation switch which provides a full decoupling from the power supply.
- If the device is not installed correctly, the warranty and liability may be voided.
- This device can be used by children from the age of 8 and above and people with reduced physical, sensory or mental capacities or lack of experience and knowledge if they are being supervised or instructed in how to use the device in a safe manner and if they understand the dangers involved.
- Children are not permitted to play with the device. Cleaning and maintenance may only be carried out by children if they are supervised.
- If the utility cord is damaged, it must be replaced by the manufacturer, service personnel or similarly qualified persons to avoid danger.
- Warning: If the surface is cracked, the device must be turned off to avoid the risk of electric shock if this crack is on hob plates made of glass ceramics or similar materials that protect active components.
- Metal objects such as knives, forks, spoons and lids may not be placed on the hob surface as they can get hot. You cannot use a steam cleaner on the device.
- Do not use a steam cleaner to clean your hob plate.
- The device is not intended to be operated using an external timer or a separate remote control system.
- WARNING: Fire hazard: Do not store objects on the hob plates.
- The cooking process must be monitored. A brief cooking process must be monitored continuously.
- WARNING: Unsupervised cooking on a hob plate with grease or oil can be dangerous and may result in a fire. NEVER ATTEMPT to put out a fire using water - instead, turn off the device and then cover the flames with, for example, a lid or else use a fire extinguisher.
- After use, turn off the hob section from its operating unit and do not trust the pot detector.
- Avoid waste - when fluids are boiling or heated, reduce the heat.
- Do not let heating units remain turned on if there are no pots or pans on them.
- When the cooking is completed, turn off the relevant zone.
- Never use aluminium foil for cooking and never place products which are wrapped in aluminium directly on the hob plate surface. The aluminium will melt and cause irreparable damage to the device.
- Never heat a can or tin container with food without opening it first - it may explode!

Operation and maintenance

Danger of electric shocks

- Never prepare food on a broken or cracked hob plate. If the hob plate surface breaks or cracks, you must immediately turn off the device on the wall switch and contact a qualified technician.
- Turn off the hob plate on the wall switch before cleaning it or carrying out maintenance work.
- Failure to comply with this recommendation may result in electric shock or death.

Health hazard

- This device complies with the safety standards for electromagnetism.
- However, people with pacemakers and other electronic implants (such as insulin pumps) should consult their doctor or the implant manufacturer before using this device to ensure that their implants will not be affected by the electromagnetic field.
- Failure to comply with this recommendation may result in death.

• Danger of hot surfaces

- During use, accessible parts of this device will become hot enough to cause burns.
- Do not let any part of your body or clothes or any objects other than kitchen gear come into contact with the induction glass until the surface has cooled.
- Keep away children.
- The handles on pots may be hot when touched. Make sure that the pot handles do not stick out over hob plates that are turned on. Keep the handles inaccessible to children.
- Failure to comply with this instruction may result in burns or scalding.

Be careful not to cut yourself!

- The sharp blade on a hob plate scraper is exposed when the safety cover is retracted. Use with extreme caution and always store it in a safe place inaccessible to children.
- If you are not careful, you may get an injury or a cut.

Important safety instructions

- Never leave the device unsupervised when it is in use. If something boils over, it may cause smoke or grease splashes which may ignite.
- Never use the device as a worktop or as a place to store things.
- Never place objects or tools on the device.
- Never place magnetic objects (such as credit cards, memory cards, etc.) or electronic devices (computers, MP3 players, etc.) near the device as they may be affected by its electromagnetic field.
- Never use the device to heat up a room.
- After use, you must always turn off the cooking zones and hob plates as described in these instructions (i.e., use the touch buttons). Do not trust the POT DETECTION feature to turn off the hob plates when removing pots.
- Do not allow children to play with the device or to sit on it or climb on it.
- Do not store items that may be of interest to children in cabinets above the device. Children who climb on top of the hob plate may be seriously injured.
- Do not leave children alone or unsupervised in the area in which the device is being used.
- Children or people with a disability that impacts their ability to use the device must have a responsible and competent person to instruct them on how to use it. The responsible person must be satisfied that they are able to use the device without endangering themselves or their surroundings.
- Do not repair or replace any parts of the device unless this is specifically recommended in the manual. All other maintenance work should be carried out by a qualified technician.
- Do not place or let go of heavy objects on your hob plate.
- Do not stand on your hob plate.
- Do not use put with sharp edges and do not drag pots across the induction glass surface as this may scratch the glass.
- Do not use rough scouring pads or other rough cleaning tools to clean your hob plate as these may scratch the induction glass.
- This device is intended for use in households and other similar environments such as:
 - staff kitchens in stores, offices and other working environments,
 - patio houses, customers in hotels, motels or other residential areas,
 - bed and breakfast environments.

WARNING: The device and its accessible parts become hot when in use.

- Be careful to avoid touching the hot components.
- Children under the age of 8 must be kept away from the device unless they are being continually monitored.
- The room must be properly ventilated when the hood is used together with other flammable devices using gas or the like.
- The hood must be regularly cleaned both on the inside and outside (AT LEAST ONCE PER MONTH) and done correctly in accordance with the maintenance instructions.
- Failure to comply with the rules for cleaning the hood and replacing and cleaning filters will result in a fire hazard.
- It is strictly forbidden to flambé food. Open flames may damage the filters and pose a fire hazard - therefore, avoid flambéing completely. You must also be extra careful when frying food to prevent the oil from overheating and igniting.
- CAUTION: When the hob plate is turned on, the accessible parts of the hood may become hot.
- Regarding the technical and safety-related precautions that need to be taken to extract fumes, you must strictly follow the rules issued by local authorities.
- The extracted air may not be carried through the same ducts used to extract vapours generated by the burning of gas or other flammable materials. Never use the hood unless the grill is correctly assembled!
- Only use the fastening screws that were provided with the product for installation - if they were not provided with the product, buy the correct type of screws. Use screws with the correct length as stated in the installation instructions.
- When the hood is used together with other devices that are not powered by electricity, the negative pressure in the room may not exceed 4 Pa (4×10^{-5} bar). This can be achieved when the air needed for combustion can penetrate through non-sealable openings, i.e. doors, windows, ventilation boxes or other technical means. A ventilation box will not on its own ensure that the limits are complied with.
- Recommendations for correct use to minimise environmental impacts: When you start cooking, turn on the hood at the minimum speed setting and let it run for a few minutes even after you are done cooking. Only increase the speed if there is a lot of vapour and only use the Boost function in extreme cases. To keep the odour reduction system running effectively, you must replace the carbon filters as needed. (If installed). (Only recirculation).
- To ensure a high performance of the grease filter, it must be cleaned as needed. To improve the efficiency and minimise noise, you must use the maximum pipe diameter specified in these instructions.
- Letting grease or oil cook on an unsupervised hob plate may be dangerous and cause fires.
- Never let hot oil or grease be left unsupervised.
- Never operate the device without the grease filter.
- Never work with open flames close to the device (for example, flambéing) around the grease filters.
- Do not install the device close to a fireplace or heating use (for example, using wood or coal) unless the fireplace or stove has a closely sealed and non-removable cover. There must not be any free-flying sparks.
- Let the device cool down before you clean it.
- If hot fluids penetrate into the device, you must only remove the grease filter or the overfilled container when the device is cooled down.
- There may be a slight odour when unpacking - this is normal and it will soon disappear.
- The hood and other ventilation systems may impact safety when operating devices that burn gas or other fuels (including those in other rooms) due to the return flow of flammable gases. These gases may result in carbon dioxide poisoning. After the installation of a hood or another kind of ventilation system, the operation of gas devices must be tested by a competent person to ensure that there is no return flow of flammable gases.
- If cleaning is not carried out in accordance with the instructions it may pose a fire hazard.
- CAUTION: Accessory components may become hot when used together with cooking devices.
- The rules regarding the exhaust of air must be complied with.
- CAUTION: This device is not intended to be used with a gas stove.

Explanation of symbols



Danger

This symbol means that there is a danger to life and health due to extremely flammable gas.



Warning about electric voltage

This symbol means that there is a danger to life and health due to voltage.



Warning

This symbol means that if a hazard cannot be avoided it may result in serious injury or death.



Careful

This symbol means that there is a low-risk hazard which if it cannot be avoided may result in minor or moderate injury.



Please note

This symbol means that there is important information to consider (for example, about damage to property) but that there is no hazard.



Follow the instructions

This symbol means that only a service technician should operate and maintain the device in accordance with the instructions.

Read the safety instructions carefully before using the product and store them in close vicinity to the area of installation or product for later use!

SPECIFICATIONS

Hob plate	Heat 80 R	
Cooking zones	4	
Voltage	220-240V~ 380-415V 3N~ 50Hz or 60Hz	
Installed effect	7400W	
Product dimensions L × W × H (mm)	800×520×230	
Installation dimensions A×B (mm)	750×490	
Motor	Brushless DC electric motor	
Extraction	Direct exhaust (to the open air)	Minimum setting at normal operation 350 m ³ /t Maximum normal setting 560 m ³ /t Boost setting 630 m ³ /t
	Recirculation	Boost setting 547 m ³ /t
Sound level	Direct exhaust (to the open air)	Minimum setting at normal operation 56 dB Maximum normal setting 68 dB Boost setting 71 dB
	Recirculation	Minimum setting at normal operation 62 dB Maximum normal setting 69 dB Boost setting 72 dB
Energy efficiency	Efficiency index	49.6
	Efficiency class	A
Grease filtering	Filtration efficiency	80.4%
	Filtration class	C

Weight and dimension figures are approximate figures. As we are constantly striving to improve our products, we may change specifications and designs without prior notice.

The diameter of the base for induction cooking gear

Induction zone	Minimum	Maximum
1 & 2 & 3 & 4	120	200
Flex zone	120	220*380

*Please note: To activate the pot detection function, the pot/cooking gear must be placed within the “a” or “b” zones - not between them.

OVERVIEW OF YOUR PRODUCT

As viewed from above

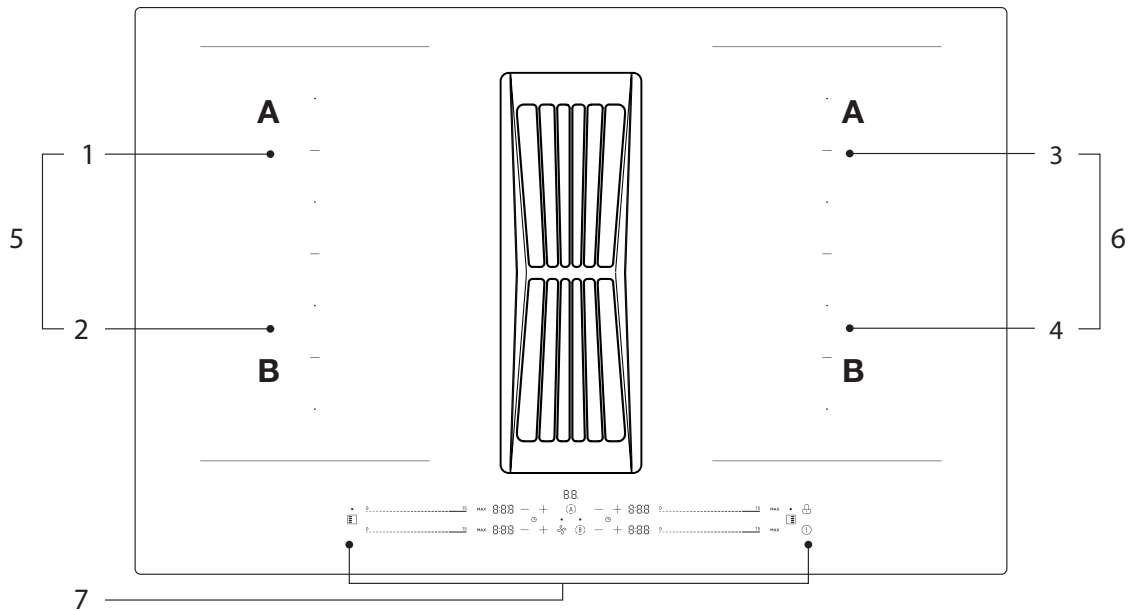

- 1. Maximum 2200/3600 W zone
- 2. Maximum 2200/3600 W zone
- 3. Maximum 2200/3600 W zone

- 4. Maximum 2200/3600 W zone
- 5. Maximum 3300/3600 W zone
- 6. Maximum 2200/3700 W zone

- 7. Operating panel

Operating panel

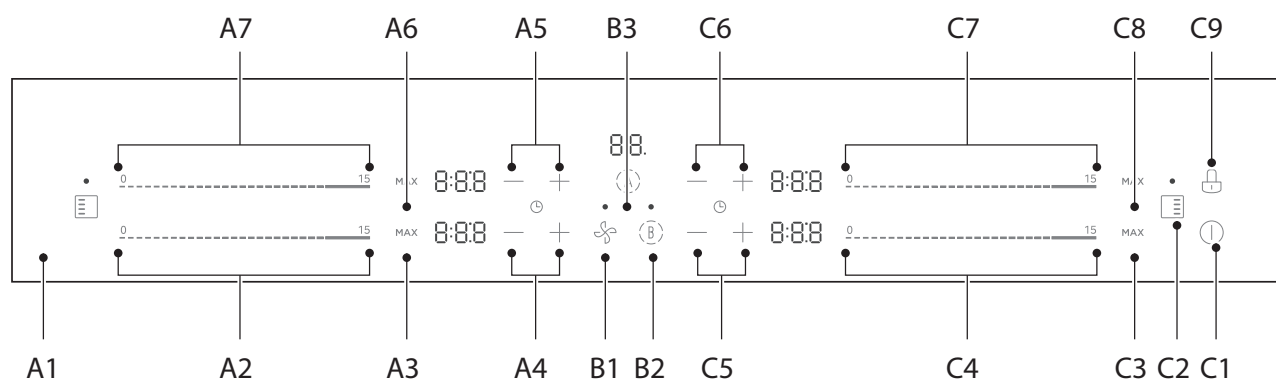

A1: Bridge function (Flex)
 A2: Indicator for heat stages
 A3: Boost
 A4: Indicator for time setting
 A5: Indicator for time setting
 A6: Boost
 A7: Indicator for heat stages

B1: Indicator for hood
 B2: Boost - hood
 B3: Auto hob plate and hood

C1: ON/OFF
 C2: Bridge function (Flex)
 C3: Boost
 C4: Indicator for heat stages
 C5: Indicator for time setting
 C6: Indicator for time setting
 C7: Indicator for heat stages
 C8: Boost
 C9: Lock keys

A3 + Ab + C3 + C8: Boost - hob plate

PLEASE NOTE:

All pictures in these instructions are only indicative. If there are any deviations between the actual product and the illustration, the actual product is what should be considered.

How it works

Induction is a safe, advanced, efficient and energy-optimising technology. Induction works by having electromagnetic vibrations generate heat directly to the pan/pot instead of directly via heating the glass surface. The glass only gets hot because at some point the pan/pot will begin heating it.

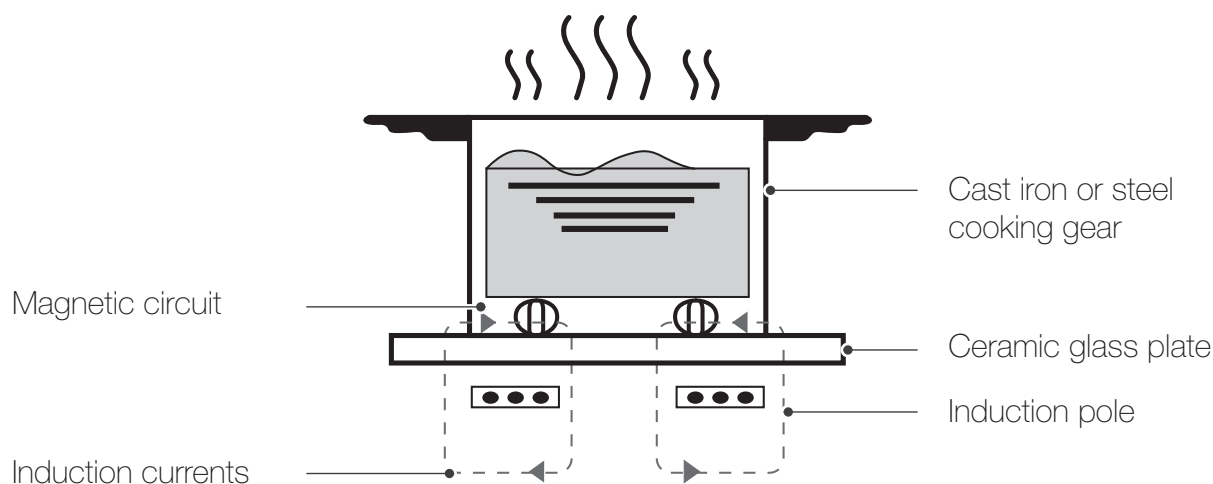

Operation

You can use the product either with an exhaust to the open air or with recirculation.

Exhaust to the open air

The hood is designed to remove vapour and smoke from the kitchen. This requires the installation of a ventilation duct to bring the absorbed air out into the open.



The air may not be sent out via a chimney used to remove vapours from devices that burn gas or other fuels (this does not apply to devices that only direct the air back into the room).

- If the exhaust air is to be carried through a non-functional smoke or exhaust chimney, you must get consent from the responsible heating engineer.
- If the exhaust air is to be carried through an outer wall, a telescopic duct should be used.

Recirculation

The air that is extracted is cleaned by the grease filters and an air filter and directed back into the room.



To encapsulate the air in recirculation, you need to install a carbon filter.

QUICK GUIDE

 Be careful when frying, as oil and grease heat up quickly, especially if you are using PowerBoost. At extremely high temperatures, oil and grease will spontaneously combust and this poses a serious fire hazard.

TIPS for cooking

When the food begins boiling, the temperature should be reduced.

- Using a lid will minimise the preparation time and save energy by better maintaining the heat level.
- Minimise the use of fluid or fat to reduce preparation times.
- Start by preparing the food at high temperatures and then reduce the temperature as the food is cooked through.

Simmering food, cook rice

Simmering food is prepared below the boiling point at approximately 85°C where only tiny bubbles simmer to the surface of the fluid that is being cooked. This is the key to preparing tasty soups and tender pot dishes because the taste develops without the food being overcooked. You should prepare sauces based on eggs and flour below the boiling point.

- Some types of cooking, like preparing rice via the absorption method, may require a setting that is higher than the lowest setting to ensure that the food is prepared correctly within the recommended time frame.

Frying steaks

To prepare juicy and flavourful steaks:

Let the meat rest at room temperature for approximately 20 minutes before preparing it.

Heat up a heavy frying pan.

Brush both sides of the steak with oil. Drip a small amount of oil into the hot pan and then place the meat on the hot pan.

The steak should only be flipped once during the frying process. The exact frying time will depend on the thickness of the steak and whether you prefer it rare, medium, etc. The frying times may vary from 2-8 minutes per side.

Press down on the steak to determine how much it is cooked - the firmer it feels, the more cooked it will be.

Let the steak rest on a hot plate for a few minutes so that it becomes tender before serving.

Frying wok dishes

1. Select a flat-bottomed wok or a large frying pan compatible with induction stoves.
2. Have all ingredients and equipment ready. Wok frying needs to be a fast process. If you are preparing large amounts of food, prepare it in several small portions.
3. Preheat the pan briefly and add two tablespoons of oil.
4. If there is meat, prepare this first, set it aside and keep it warm.
5. Wok frying vegetables When the vegetables are warm but still crispy, turn down the heat, add the meat back into the wok and add your sauce.
6. Stir the ingredients carefully to ensure that they are cooked through.
7. Serve immediately.

Registration of small objects

When an unsuitable size or non-magnetic pot (for example, one made from aluminium) or another small object (such as a knife, fork, key, etc.) have been left on the hob plate, the hob plate will automatically enter standby mode after 1 minute. The ventilator will continue cooling down the induction hob plate for an addition 1 minute.

Heat stages

The settings below are only guidelines. The precise setting will depend on several factors, including your kitchen gear and the amount of food you are preparing. Experiment with the induction hob plate to find the settings that best suit your needs.

Heat stages	Suitable settings
1-2	<ul style="list-style-type: none">• Delicate heating of small amounts of food• Melting chocolate, butter and foods that quickly get burnt• Gentle simmer• Slow heating
3-5	<ul style="list-style-type: none">• Quick heating• Quick simmer• Cooking rice
6-11	<ul style="list-style-type: none">• Pancakes
12-13	<ul style="list-style-type: none">• Sautéing• Cooking pasta
14/P	<ul style="list-style-type: none">• Stirring (frying)• Browning• Bring the soup to a boil• Boiling water

Selecting installation equipment

Cut the worktop based on the sizes shown on the schematic.

For installation and use purposes, there must be kept a minimum of 5 cm of space around the hole.

Make sure the thickness is at least 30 mm. Please select heat-resistant and insulated materials. (Wood and similar fibre-based or hygroscopic materials may not be used unless these are impregnated) to avoid electric shocks and major deformations caused by the heat radiating out from the hob plate.

See below:



Please note: The safety distance between the sides of the hob plate and the interior sides on the cabinet must be at least 3 mm.

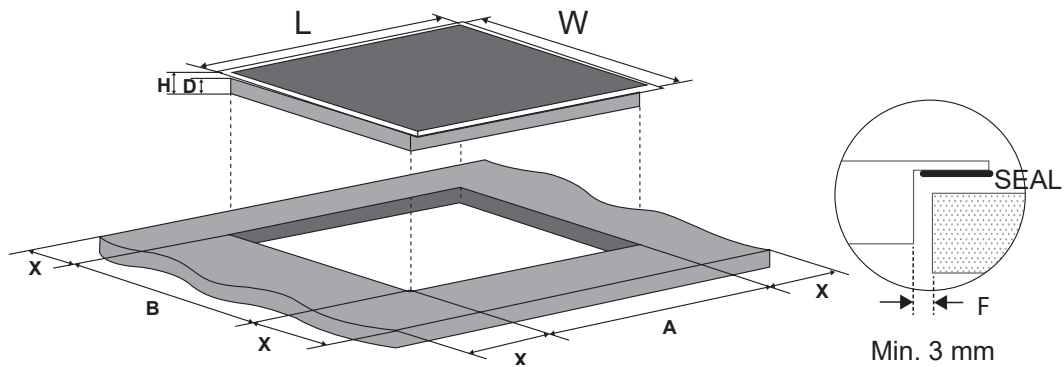

L (mm)	W (mm)	H (mm)	D (mm)	A (mm)	B (mm)	X (mm)	F (mm)
800	520	230	226	750+2 +0	490+2 +0	50 min.	3 min

You must always ensure that the hob plate is well ventilated and that the air intake and exhaust pathways are not blocked. Make sure that the ceramic hob plate is optimally installed for work purposes.

See below:



Please note: The safety distance between the hob place and a cabinet above it should be at least 760 mm.

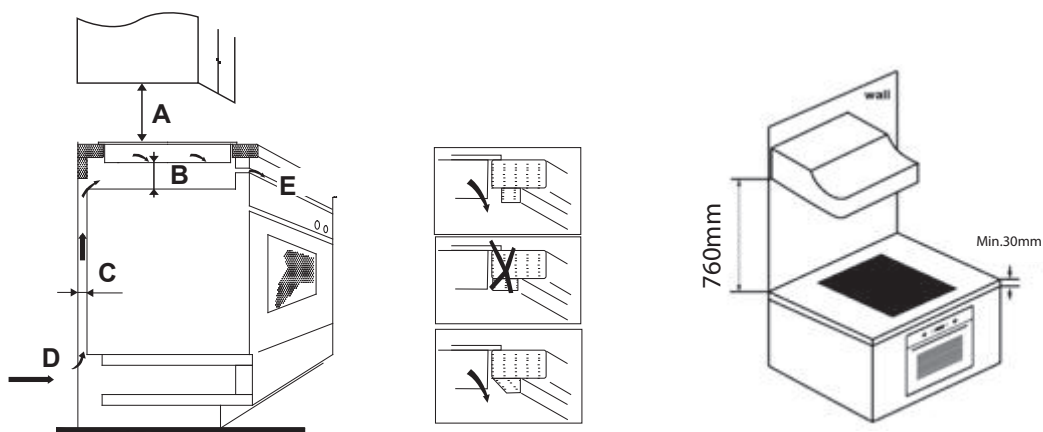

A (mm)	B (mm)	C (mm)	D	E
760	50 min.	20 min.	Air intake	Air exhaust 5 mm

Warning: How to ensure sufficient ventilation

Make sure that the induction hob plate is well ventilated and that the air intake and exhaust paths are not blocked. To avoid unintentionally touching the heated surface of the hob plate and to avoid the risk of electric shock while cooking, it is necessary to install a wooden insert fastened with screws with a minimum distance of 50 mm from the bottom of the hob plate. Follow the requirements below.

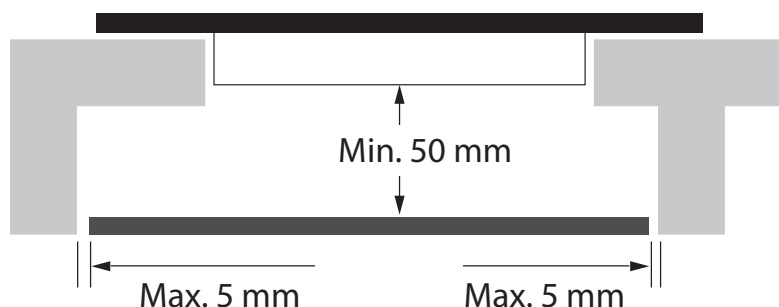

There are ventilation holes around the edges of the hob plate. You **MUST** make sure that these holes are not blocked by a cabinet when placing the hob plate.



- Make sure that the glue connecting plastic or wooden materials to the product are able to withstand temperatures of at least 150 °C to prevent the cover from loosening.
- The rear wall and adjacent/nearby surfaces must therefore be able to withstand temperatures of 90°C.

Before installing the hob plate, you must ensure the following:

- That the worktop surface is quadratic and even and that no structural elements impede the space requirements.
- That the worktop surface is made from a heat-resistant and insulated material.
- If the hob plate is installed on top of an oven, make sure that the oven has an integrated ventilator/cooler.
- That the installation will comply with all requirements for distance and the applicable standards and regulations.
- That there is a properly insulated switch which provides a full decoupling from the power supply integrated into the permanent cord and that this is installed and placed in accordance with local wiring rules and regulations.
- The insulation switch must be of an approved type and offer 3 mm of free space from the switch in all poles (or in all active [phase] conductors if the local wiring regulations allow for this variation of the requirements). The insulation switch will be easily accessible to the customer with the hot plate installed.
- You should contact local building authorities and inspect the bylaws if you are not sure about the installation.
- That you use heat-resistant surfaces that are easy to clean (such as ceramic tiles) on the wall surfaces around the hob plate.

After installing the hob plate, you must ensure the following:

- That the power cable is not accessible via cabinet doors or drawers.
- That there is sufficient ventilation of fresh air outside of the cabinet construct to the bottom of the hob plate.
- If the hob plate is installed on top of a drawer or cabinet, there must be installed a thermal protection barrier under the hob plate.
- That the insulation switch is easily accessible to the customer.

Before placing fittings

The device must be placed on a stable and even surface (use the packaging).
Be careful not to add weight to or press down on the glass.

Caution

- The induction hob plate must be installed by qualified personnel or technicians. Please never attempt to do this yourself.
- The hob plate must not be installed directly on top of a dishwasher, refrigerator, freezer, washing machine or dryer as the moisture may damage the electronic components of the hob plate.
- The induction hob plate must be installed in such a manner that heat can radiate well to ensure reliability.
- The wall and the induction heating zone on top of the table top must be heat resistant.
- To avoid injury, the self-adhesive tape must be heat resistant.
- It is not permitted to use a steam cleaner.

Attach the hob plate to the main power supply.

Please read the manual and these safety instructions carefully before using the product and before installing the hob plate. There is important information about safety, installation, how to use and maintenance which products both people and the product.



- This hob plate may only be connected to the main power supply by a suitably qualified person.
- The product is only intended for ordinary household use.
The manufacturer/importer is not liable for damage caused by incorrect use or operation.
- Before connecting the product to a power source, it should be ensured that the connection matches the connection data (voltage and frequency) specified on the type plate. It is very important that this data matches as otherwise the product may be damaged. When in doubt, contact a professional.
- The power cord lengths for the power supply must be able to handle the load specified on the type plate.
- When connecting the hob plate to the main power supply, you cannot use adaptors or extension cords as these may overheat and pose a fire hazard. An extension cord does not provide the required amount of safety.
- The power supply cable must not touch any warm parts and must be placed so that they temperature there never exceeds 75°C.



- Have an electrician verify that the domestic electrical system is suitable without having to make any required changes.
Any changes that need to be made must only be made by a qualified electrician.



- If the total number of heating units on the device you select do not exceed 4, the device can be connected directly to the power supply with a single-phase electric connection as shown below.
- If the cable is damaged or needs to be replaced, the work must be carried out by a professional with the proper training and tools to avoid accidents.
- If the device is attached directly to the power supply, there must be installed an omnipolar breaker with a minimum opening of 3 mm between the switches.
- The installer must ensure that there has been made a correct electrical connection and the connection complies with safety regulations.
- The cable may not be bent or compressed.
- The cable must be checked regularly and must only be replaced by authorised technicians.

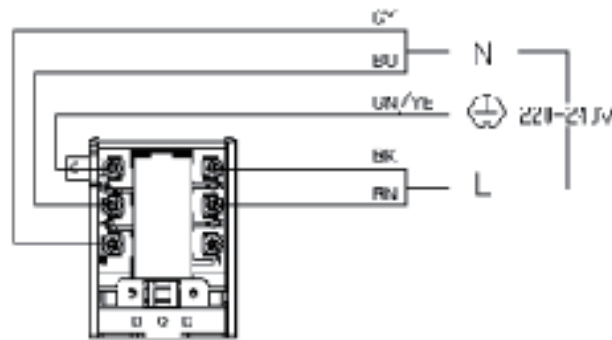

220-240V 1N~

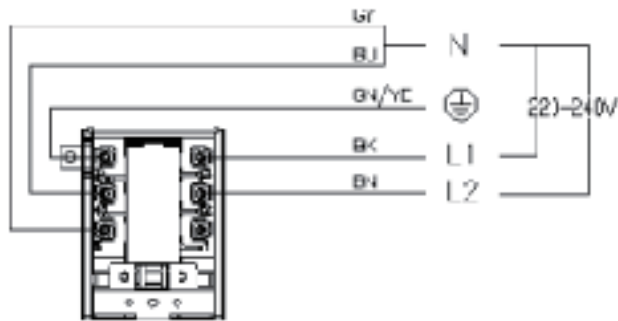

220-240V/380-415V 2N~



The bottom surface and the power cable on the hob plate are not accessible after installation.

OPERATING INSTRUCTIONS

Touch control

- The display reacts to touch, so do not press down - you just need to touch the surface.
- Use the tip of your finger instead of the finger.
- You will hear a “beep” every time a touch is registered.
- Make sure that the touch display is always clean and dry and that there are no objects (such as kitchen utensils or a rag) which cover the display buttons. Even a thin layer of water can make it hard to operate the display.

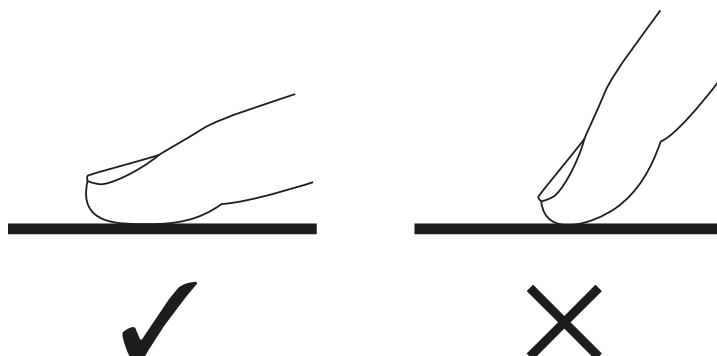

Selecting appropriate cooking gear

Only use cooking gear with bottoms appropriate for induction cooking.
Look for the induction symbol on the packaging or at the bottom of the pot.

- You can see whether your cooking gear is suitable by doing a magnet test.
Trace a magnet alongside the bottom of the pot. If the magnet is pulled in, the pot is suitable for induction cooking.

- If you do not have a magnet:
Put some water in the pot that you want to test.

If the  icon does not blink on the display and the water is heating, the pot is suitable.

- Kitchen gear made from the following materials are not suitable: pure stainless steel, aluminium or copper without a magnetic bottom, glass, wood, porcelain, ceramic and clay.

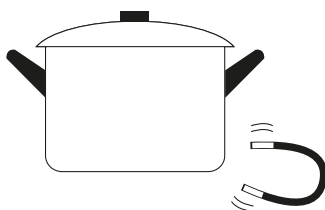

- Do not use kitchen gear with ridged edges or a curved bottom.

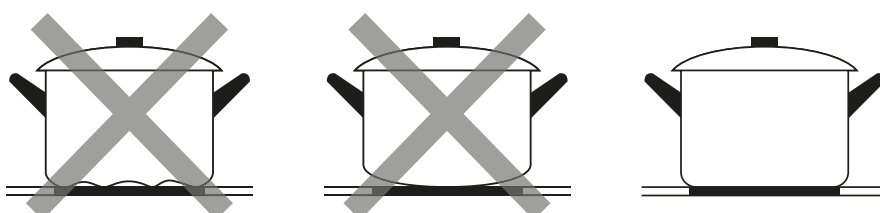

- Make sure that the bottom of your pot is smooth, flat against the glass plate and has the same size as the cooking zone. Use pots with diameters that match the graphic for the selected zone. Using a pot that is slightly wider will mean an optimal efficiency of the energy used. If you are using a smaller pot, the efficiency may be less than expected. Pots with a diameter of more than 140 mm might not be recognised by the hob plate. Always centre your pot on the cooking zone.

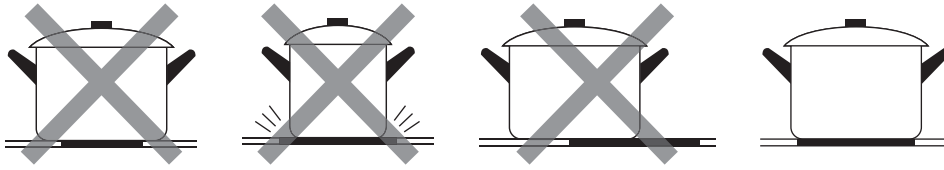

- Always lift the pots off the induction hob plate - do not push them, as they may scratch the glass.

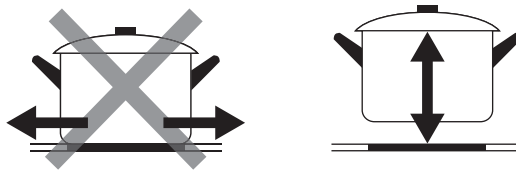

How to use the product

Begin cooking

Press the ON/OFF button for 1 second. After you have turned on the hob, the alarm will “beep” once and all displays will show “-” and thereby indicate that the induction hob plate is in standby mode.

Place a suitable pot on the cooking zone you want to use.

- Make sure that the bottom of the pot and the surface of the cooking zone are clean and dry.

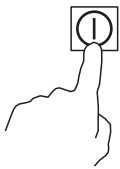

Lightly move the slider to heat control.

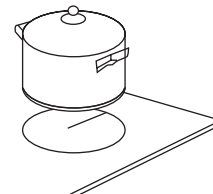

Select a heat setting by touching the slider.

- When a pot has been placed on the heating zone and you do not select a heat setting within 20 seconds, the hob plate will turn off automatically. You then need to restart from step 1.
- When a pot has not been placed on the heating zone and you do not select a heat setting within 20 seconds, the hob plate will turn off automatically. You then need to restart from step 1.
- You can change the heat settings at any time while cooking.

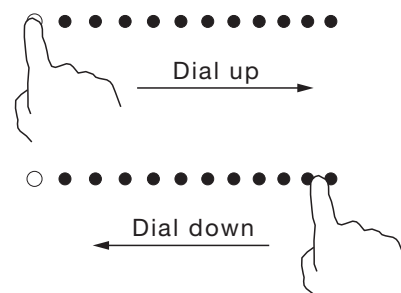

If the display blinks with the heat setting icon

This means that:

- You have not placed a pot on the correct cooking zone, or
- The pot you are using is not suitable for induction cooking, or
- The pot is too small or not placed in the centre of the cooking zone.

No heating will take place unless there is a suitable pot on the cooking area.

The display will automatically turn off after 1 minute if a suitable pot is not placed on the hob.

Manual ventilation





You can manage the ventilation setting manually.

PLEASE NOTE:

Using tall cooking gear can prevent the optimal extraction of vapour.

You can improve the extraction power by placing a lid on the cooking gear and tilting the lid.

Activation of manual ventilation

1. When the device is turned on, touch the  button to activate the ventilation system.
2. Short press the hood button  to change between level 0-3 and long press for 3 seconds on the hood button  to turn off the hood.
3. Press the  button for booster.

The ventilation system has been activated

Deactivating or changing the ventilation settings

1. Turn off.
2. Use the hood button  to adjust the level to 0.

Finish cooking

Turn off the cooking zone by moving the slider to the “0” position. Make sure that the display shows “0”.



Turn off the entire hob plate by touching ON/OFF.



The auto function for the ventilation system

The ventilation system has either a manual mode or an automatic mode. The automatic mode can be activated when the cooking zone is activated. It will automatically deactivate 2 minutes after all cooking zones have been turned off.

Manual

When the hob plate is turned on, press the  button or the  button. The screen will display level 0-3 or b.

Automatic

When the hob plate is turned on, press the  button. The display will show A. The hob plate will deactivate the auto function when:

- 2 minutes have passed after all zones were turned off
- you press the power button.

Activate the boost function

Touch the MAX button. Make sure that the display shows **MAX**

Deactivate the boost function

Touch the heat control slider when you want to deactivate the boost function.

Turn off the entire cooking zone by pressing ON/OFF.



The function works on all cooking zones.

- The cooking zone will return to its original setting after 10 minutes.
- If the original heat setting is 0, it will return to the maximum level after 10 minutes.
- If the front left cooking zone is set to boost and the rear left cooking zone is then set to boost as well, the front left and rear left cooking zone will both be set to level 15.

Intensive ventilation

- The ventilation system has intensive settings. If you activate the intensive settings, the ventilation system will work at maximum capacity.

Activating the intensive ventilation:

1. Touch 

2. “b” will be shown.

- Changing or deactivating the intensive ventilation setting.
- Use the  button to select the desired intensity in the settings area or configure to 0.

Automatic start of the ventilation system

If you select an effect level for a cooking zone and the automatic start is activated, the ventilation system will start at an effect level equivalent to the effect level of the cooking plates.

Flexible area

This area can be used as an individual zone or as two different zones depending on what is required for cooking.

- The flexible area consists of two independent inductors that can be controlled separately. When it works as an individual zone, the part that is not covered by kitchen gear will turn off automatically after 8 seconds.
- To ensure a correct pot detection and an even heat distribution, the kitchen gear must be placed correctly:

In the front or rear side of the flexible area when the cooking gear is less than 21 cm.

Larger cooking gear can be placed anywhere.

As a large zone

To activate the flexible area as one large zone, you just need to press the bridge function (A1).



The power setting works like with any other area.

To add another pot, press the relevant buttons again to register the cooking gear.

Using two independent zones

To use the flexible area as two different zones with different effect settings, press the bridge function (A1).

Locking the control functions

- You can lock the control functions to prevent unintended use (for example, to prevent children turning on the cooking areas by accident).
- When the control function is locked, everything except the ON/OFF buttons are deactivated.

How to lock the control functions	
Press and hold the lock control function for approximately 3 seconds	The display will show "Lo"

How to unlock the control functions	
Press and hold the lock control function for approximately 3 seconds	

When the hob plate is locked, all controls are deactivated except the ON/OFF button. 

You can always turn off the induction hob plate using the ON/OFF button  in an emergency, but you need to unlock the hob plate again before using it another time.

The power supply function

- It is possible to specify a maximum limit for the effect absorption on the hob plate by selecting several different effect areas.
- The induction hob plate is capable of specifying an automatic limit for the effect level while in operation to avoid the risk of an overload.

Access the power supply function

State: Configure child proofing in a turned off state.

Settings:

Conditions:

1) LR max, burns MAX, select button 3 seconds (+Buzzer sound)

P0

2) LF max, burns MAX, select button 3 seconds (+Buzzer sound)

74

00

Settings:

Change to another level

1) Select the effect limitation value with the lock  button (the effect limitation value is based on the specifications).

There are 5 effect levels, ranging from "2.8k" to "7.4k".
The LR and RF display will show one of them.

"28 00": The maximum effect is 2.8 kW.

"35 00": The maximum effect is 3.5 kW.

"45 00": The maximum effect is 4.5 kW.

"58 00": The maximum effect is 5.8 kW.

"74 00": The maximum effect is 7.4 kW.

Confirmation and conclusion of the power supply function

After you have selected the effect limitation, use the ON/OFF button (ⓘ) to confirm.
The hob plate will then turn off.

Timer control

- You can configure this to turn off one or more hob plates after the specified time has passed.
- The maximum time setting is the applicable standard time setting for the current level.
See the table to find information about standard operating times.

Configure the timer to turn off the cooking zones

Configure a zone

Lightly move the slider to heat control.



When the timer is set, it will begin to count down immediately. The display will show the remaining time and the timer indicator will blink for 3 seconds.

0:30

Configure the timer by pressing “-” or “+”.

Tip: Touch “-” or “+” once on the timer to decrease or increase the time by 1 minute.
Touch and hold “-” or “+” on the timer to reduce or increase the time by 10 minutes.



Once the preparation time is over, the associated cooking zone will turn off automatically.

Configure multiple zones:

The steps to configure multiple zones are the same as the steps to configure a single zone - the timing for each heating zone needs to be configured and shown for each individual zone.

Shown as below:

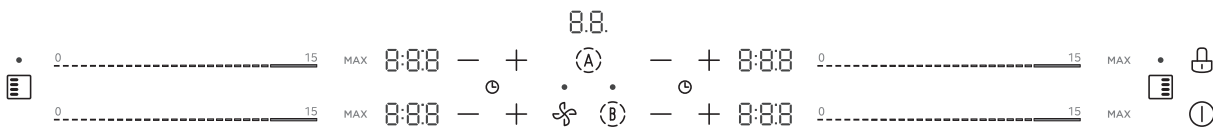

Cancelling the timer

The configured time on the timer which matches the heating zone is 0.

Press and hold “-” and “+” for 1 second on the timer to cancel it.





PLEASE NOTE:

- 1) The manual time setting cannot exceed the predetermined time setting for the hob plate. If the current value is reduced after having specified the maximum time setting, the time setting will automatically change to the standard maximum time for the current level when the time setting is longer than the standard completion time for the current level.
- 2) When setting the timer, press the slider once to see the current heating level. After having access the displayed heating level, click on or push the slider to specify the level.

Standard operating times

Auto shutdown is a safety feature for your induction hob plate. The function will automatically shut down the hob plate if you ever forget to turn it off. Standard operating times for different effect levels are shown in the table below.

Effect level	1	2	3	4	5	6	7	8	9
Standard operating times (hours)	480	480	480	360	360	360	240	240	240
Effect level	10	11	12	13	14	15			
Standard operating times (hours)	120	120	120	90	90	90			

Important! People with a pacemaker should consult their doctor before using this device.

CLEANING AND MAINTENANCE

To keep your device operating efficiently for a long time, it is important to clean and maintain it carefully.

Cleaning the hob plate

What?	How?	Important!
<p>Everyday dirt on the glass surface (finger prints, stains, food residue or other non-sweet residue on the glass)</p>	<ol style="list-style-type: none"> 1. Turn off the power to the hob plate. 2. Add a hob plate cleaning agent while the glass is still warm (but not burning hot!). 3. Clean and dry with a clean cloth or paper towel. 4. Turn the power to the hob plate on again. 	<ul style="list-style-type: none"> • When the power to the hob plate is turned off, there will be no “warm surface” indicator - but the cooking area may still be hot! Be extremely careful. • Rough scouring pads, some nylon scouring pads and strong/abrasive cleaning agents may scratch the glass. Read the label to see whether your cleaning agent or scouring pad is suitable. • Never let any residual cleaning agents remain on the hob plate - the glass may become stained.
<p>Overcooked, melted ingredients and warm sugary residue on the glass.</p>	<p>Immediately remove these with a palette knife, spatula or scraper suitable to use on glass ceramic surfaces - but be attentive to hot surfaces:</p> <ol style="list-style-type: none"> 1. Turn off the power to the hob plate on the wall switch. 2. Keep the blade or other tool in a 30° angle and then scrape off the dirt on a cool surface of the hob plate. 3. Clean dirt or residue with a kitchen towel or a paper towel. 	<p>Remove stains from melted ingredients and sugary food or waste as soon as possible. If such stains are allowed to cool down on the glass, they may be difficult to remove or even permanently damage the surface of the glass.</p> <ul style="list-style-type: none"> • Danger: When the safety cover is pulled back, the blade is razor sharp! Therefore, always use the scraper with extreme caution and always store it safely and outside the reach of children.
<p>Residue on the touch buttons</p>	<p>Turn off the power to the hob plate. Clean up the residue. Dry the touch screen area with a clean moist sponge or rag. Dry the area completely with a paper towel. Turn on the power to the hob plate again.</p>	<ul style="list-style-type: none"> • The hob plate may beep and turn off by itself and the touch screen may not work as long as there is fluid in the area. Make sure to completely dry the touch screen area before turning the hob plate on again.

Components that need to be cleaned or replaced

The following overview shows the components in the device that you either need to replace or clean.

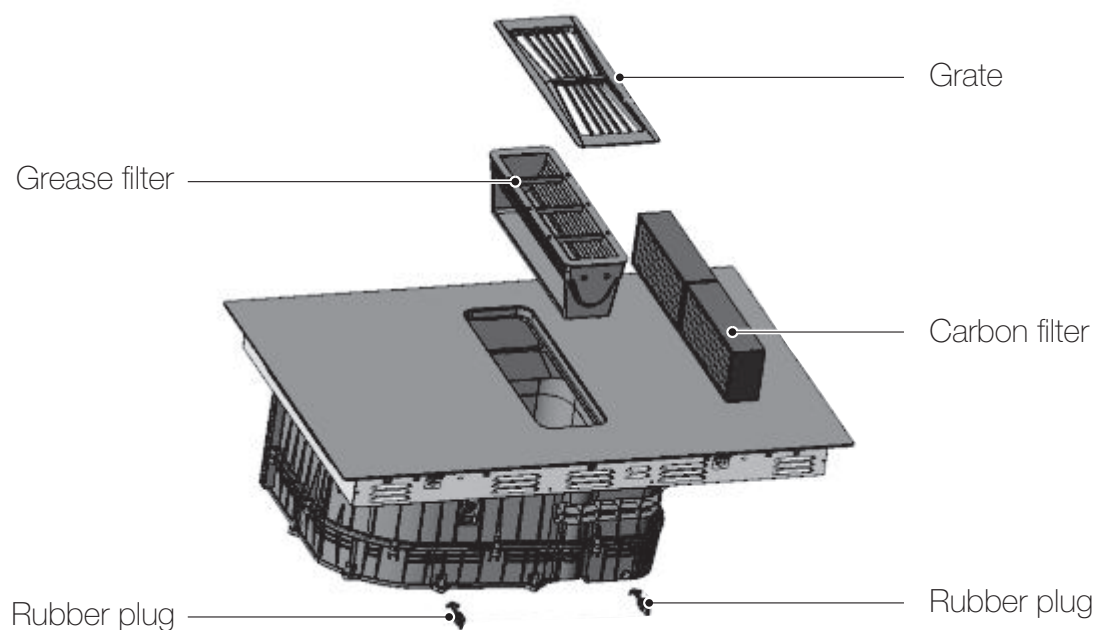

Replace odour filter

Replace carbon filter (Carbon filter not included)



PLEASE NOTE

You can buy carbon filters from specialist retailers or customer service.

1. To keep the filters in good condition you should only use original filters.

2. **IMPORTANT!**

If grease filters or grates fall down, they may damage the hob plate underneath them. Remove the grate and grease filter and dispose of them correctly.

- Grease may build up at the bottom of the container. Keep the grease filter in a horizontal position to prevent grease from dripping.

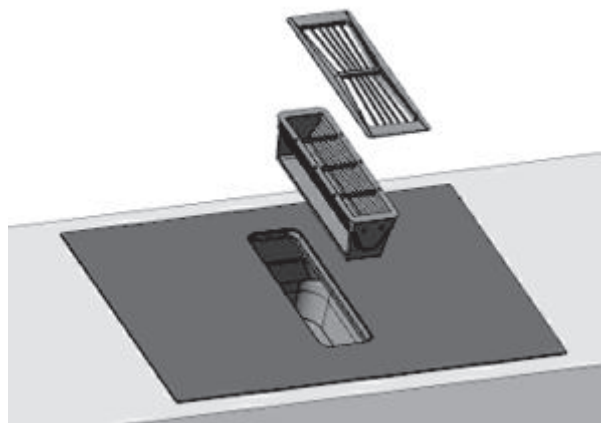

3. Remove the two carbon filters and dispose of them correctly.

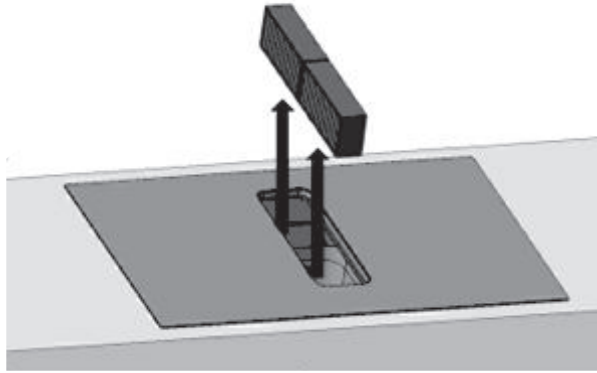

4. Insert two new carbon filters on the left side of the device.

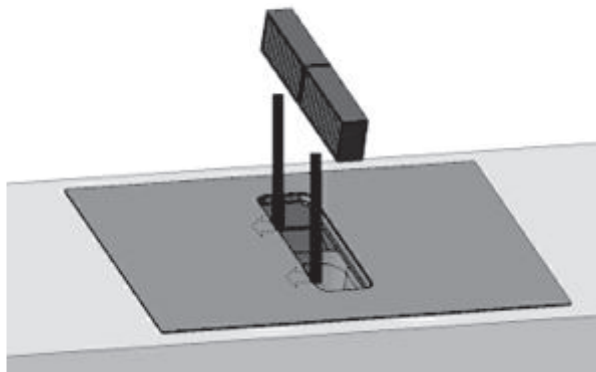

5. Insert the grease filter and cover the grate.

Resetting the saturation indicator

This requires the following: After the device is turned off, F will light up.

1) Replace the carbon filter

2) When the device is turned off, press the lock button and hold it for 3 seconds to lock.

3) Press and hold  for 3 seconds to reset the carbon filter and the hood display will then show "CL".

Cleaning the grate and grease filters

The grease filters filter out grease from the vapours that come from cooking. To keep them in good working order, you must regularly clean the grease filters as grease and dirt residue may reduce the functionality of the hood. The filters must be cleaned or replaced at regular intervals.

WARNING! Fire hazard! An oversaturated grease filter may pose a fire hazard!

- Never operate the device without a grease filter.
- Clean the grease filter on a regular basis.
- Never work with open flames near the device (for example, do not flambé).
- Never install the device near fireplaces or stoves using hard fuel (for example, wood or coal) unless the device has a sealed and non-removable cover. There must not be any free-flying sparks.

1. IMPORTANT!

If the grease filters fall down, they may damage the hob plate beneath them.

Remove the grate and grease filter and dispose of them correctly.

- Grease may build up at the bottom of the container. Keep the grease filter in a horizontal position to prevent grease from dripping out.

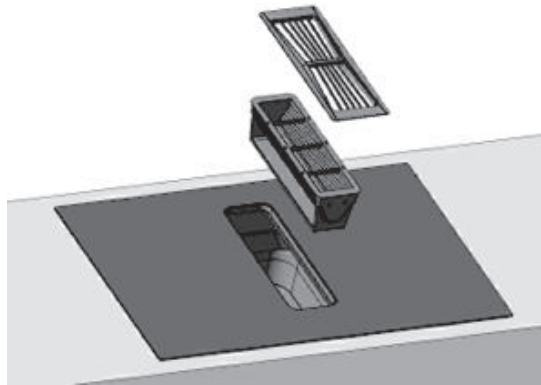

2. Clean the grate
3. Clean the grease filters
4. If necessary, remove the carbon filters and clean the hob plate on the inside.
5. If objects enter the device, they must be removed. Make sure that the path to the overflow container is not blocked.
6. Dry the inside of the hob plate with soapy water and a soft rag.
7. After cleaning, reinsert the dry metal grease filter.

Manual cleaning of grease filters/grate

1. Let the grease filter or grate soak in warm soapy water.
2. Use a brush to clean the grease filter or grate. Do not use very potent, acidic or alkaline cleaning products. Use a special grease dissolving cleaning agent to clean dirt that is hard to remove.
3. Flush the grease filters thoroughly.
4. Let fluids from the grease filter drip off.

Cleaning the grease filter in a dishwasher

1. Place the grease filters loosely in the dishwasher - do not stack them together tightly. For optimal cleaning results, you should place the grease filter with the filter side down in the dishwasher. Do not clean very dirty grease filters together with other kitchen gear. Do not use very potent, acidic or alkaline cleaning products.
2. Start the dishwasher. Select a temperature that is no higher than 70°C.
3. Let fluids from the grease filter drip off.

Clean the cavity and the drain

Please note: Fluids or objects may seep into the hob plate from above via the rubber plug.

It is necessary to let the device cool down and for the residual heat indicator to be turned off before doing the following:

1. Pull out the rubber plug with one hand and hold on to the container with the other hand. Drain fluids or objects from the rubber plug.
2. Make sure that the path to the rubber plug is not blocked before putting it back into place. Remove any potential items that have gotten into the device when it is cooled down. To do this, you need to remove the grease filter.

TROUBLESHOOTING

When using your device there may occur errors and functions may not work properly. The following overview contains potential causes and solutions for error messages or functions that do not work properly. It is recommended to read the overview below carefully to save yourself the time and money it may take to call the service centre.

Problem	Potential cause	Potential solution
The hob plate cannot be turned on.	There is no power.	Make sure that the ceramic hob plate is attached to the power supply and switched on. Check if there is a power outage in your home or local area. If you have checked everything and the problem persists, call a qualified technician.
The touch screen is not reacting.	The touch screen may be locked.	Unlock the touch screen. See the "Operating panel" section on page 33.
The touch screen is hard to operate.	There may be a film of water on top of the touch screen or else you are using too much of your finger when pressing the touch screen icons.	Make sure that the touch screen is dry and use only your fingertip when pressing the touch screen icons.
The glass is scratched.	Rough, edged cooking gear There has been used unsuitable abrasive scouring pads or cleaning products.	Use cooking gear with a flat and smooth bottom. Find information about this in these instructions.
Some pots are making crackling or clicking sounds.	This may be due to how the cooking gear is made (potentially with layers of different materials that vibrate at different frequencies).	This is completely normal for cooking gear and does not mean that something is wrong.
The induction hob plate is making a humming sound when the heat setting is turned up a lot.	This is due to the induction technology itself.	It is completely normal, but the noise should be reduced or disappear completely when you dial down the heat setting.
Ventilator noise is coming out from the induction hob plate.	An integrated cooling ventilator in the device has been activated to prevent the overheating of electronic components. It may continue to operate even after you have turned off the induction hob plate.	This is normal and you do not need to do anything about it. Do not turn off the power to the induction hob plate on the wall while the ventilator is operating.
Pots are not heating up and this is shown on the display.	The induction hob plate cannot register the pot because the pot is not suitable for induction heating. The induction hob plate cannot register the pot because it is too small for the cooking area or is not placed correctly in a central position.	Use cooking gear that is suitable for induction heating. Centre the pot and make sure that the bottom matches the size of the cooking zone.
The induction hob plate or cooking zone has unexpectedly turned off, a sound can be heard and an error code is shown in the timer display (typically alternately with one or two digits).	Technical error.	Write down the error message and numbers, turn off the power to the induction hob plate on the wall and contact a qualified technician.

The device is equipped with a self test function. With this test, a technician can test the functionality of several components without having to take apart or remove the induction hob plate from the worktop surface.

Problem	Potential cause	Potential solution
E1, E2, E7, C1	Temperature sensor error	Contact the supplier.
E3, E4	Error on the temperature sensor by IGBT	Contact the supplier.
EU	Error between the display card and the main card	Contact the supplier.
EL, EH	Abnormal power supply voltage	Make sure that the power supply is working as normal. Turn on the power after the power supply has been normalised.
C1	The temperature sensor for the ceramic glass plate is high	Restart the device after the induction hob plate has cooled down.
C2	The IGBT temperature sensor is getting high readings	Restart the device after the induction hob plate has cooled down.
F5	Error on the cooling ventilator	Restart the device after the induction hob plate has cooled down.
B3	Abnormal temperature in the ventilation system	Restart the device after the induction hob plate has cooled down.
B5	The ventilation systems fails to start	Check the hood for foreign objects and restart it.
B7	The ventilation systems fails to start	Contact the supplier.
Bc	Error in the communication between the display card and the motor control card.	Contact the supplier.

Error codes that occur while using the device & solutions:

Problem	Potential cause	Potential solution
Auto restore		
EL, EH	The power supply voltage exceeds the nominal voltage.	Make sure that the power supply is working as normal. Turn on the power once the power supply has returned to normal.
C1	High temperature on the glass ceramic hob plate sensor.	Wait for the temperature on the glass ceramic hob plate to return to normal. Press the ON/OFF button to restart the device.
C2	The IGBT temperature sensor is getting high readings	Wait for the IGBT temperature to return to normal. Press the ON/OFF button to restart the device. See if the ventilator is operating evenly - if not, you must replace the ventilator.
B3	The power on the driver card of the hood is abnormal.	Press the ON/OFF button to restart the device.
B7	The ventilation system's air duct is completely blocked.	Press the ON/OFF button to restart the device. Inspect the hood for foreign objects and restart it.
No auto restore		
E2	An error on the temperature sensor for the ceramic hob plate. Short circuit.	Check the connection or replace the sensor for the ceramic hob plate.
E1	An error on the temperature sensor for the ceramic hob plate. Open circuit.	
E7	An error on the temperature sensor for the ceramic hob plate. Invalid.	
E4	Error on the IGBT temperature sensor. Short circuit.	Contact the service department to fix the damage.
E3	Error on the IGBT temperature sensor. Open circuit.	
B5	Error in the ventilation system	Contact the service department to fix the damage.
Bc	Error in the communication between the display card and the hood's driver card	Contact the service department to fix the damage.

Specific errors and potential solutions:

Error	Potential cause	Solution A	Solution B
The LED lights are not on when the device is connected to a power source.	There is no power.	Make sure that the plug is properly attached to the switch and that the switch is working.	
	Error in the connection between the accessory print card and the display card.	Inspect the connection.	
	The connection card is damaged.	Contact the service department to fix the damage.	
	The display card is damaged.	Contact the service department to fix the damage.	
Some of the buttons do not work / the LED display is not working normally.	The display card is damaged.	Contact the service department to fix the damage.	
The indicator for cooking mode is lit up but the heating is not starting.	High temperature on the hob plate.	The surrounding temperature may be too high. The air intake or the air valve may be blocked.	
	Something is wrong with the ventilator.	Check if the ventilator is working properly - if not, replace it.	
	The print card is damaged.	Contact the service department to fix the damage.	
The heating stops suddenly when the hob is used and the display is showing a blinking "u".	Wrong kind of pot.	Use a pot suitable for induction heating.	The pot detector circuit is damaged. Replace the print card.
	The diameter of the pot is too small.		
	The hob plate is overheated.	The device is overheated. Wait until the temperature goes back to normal. Press the ON/OFF button to restart the device.	
The heating zone on the same side (for example, the first and second zone) is displaying a "u".	Error in the connection between the print card and the display card.	Inspect the connection.	
	The communication component in the display card is damaged.	Contact the service department to fix the damage.	
	The main card is damaged.	Contact the service department to fix the damage.	
The ventilation motor is making abnormal sounds.	The ventilation motor is damaged.	Contact the service department to fix the damage.	

The above is an assessment and inspection of common errors.

Please do not take apart the device yourself to avoid injury and damage occurring to the device.

TRADEMARKS, COPYRIGHTS AND LEGAL DECLARATION

Logos, word marks, trademarks, designs and all variations thereof are valuable assets to Witt and/or its associated companies ("Witt") where Witt owns the trademarks, copyrights and other intellectual property rights and all goodwill from the use of any part of a Witt trademark. The use of the Witt trademark for commercial purposes without the prior written permission from Witt may be a trademark violation unfair competition in violation of applicable laws.

This manual was created by Witt and Witt reserves all copyrights to this manual. No entity or person may use, duplicate, change, or distribute in whole or in part this manual or package it and sell it together with other products without the prior written permission from Witt.

All described functions and instructions were updated at the time of this manual being written. However, the actual product may vary due to improvements made to functions or the design.

DISPOSAL AND RECYCLING

Important environmental instructions

Compliance with the WEEE directive and disposing of the waste product:
This product complies with the EU's WEEE directive (2012/19/EU). This product carries a classification symbol for electronic waste and electronic equipment (WEEE).

The packaging is environmentally friendly and can be reused, disposed of or destroyed without harming the environment. The packaging materials are labelled in accordance with this.

The symbol found on the product or packaging specifies that the product may not be disposed of together with common household waste. It must instead be delivered to a recycling station approved to handle electrical and electronic equipment. By disposing of the product correctly, you will help to prevent negative impacts on the environment and human health. You can find more information about the disposal and recycling of the product by contacting your municipality, recycling station or the business from which you bought the product.



COMPLIANCE DECLARATION

Restriction of Hazardous Substances (RoHS) directive

This product complies with the requirements of Directive 2011/65/EU on the limitation of the use of certain hazardous substances in electric and electronic equipment.

PACKAGING INFORMATION

The packaging materials for the product are made from recyclable materials in accordance with our national environmental regulations. Do not dispose of the packaging materials together with household waste or other types of waste. Deliver the packaging materials to the

collection sites designated by the local authorities.



DATA PROTECTION

To deliver the agreed upon services to the customer, we accept that we will comply with all provisions of the applicable data protection legislation without limits in accordance with the laws of the agreed upon countries in which services to the customer will be delivered and, where relevant, in accordance with the EU's General Data Protection Regulation (GDPR).

In general, our data processing is for the purposes of fulfilling our obligations pursuant to the contract with you and for product-related safety reasons and to protect your rights in connection with warranty issues and product registration questions. In some cases, but only if sufficient data protection can be ensured, personal data may be transferred to recipients outside of the EEA.

WARRANTY AND SERVICE

There is a 2-year warranty period if your new product stops working due to manufacturing or material faults which begins from the documented date of purchase. The warranty covers materials and the cost of labour. When inquiring about service, please state the product name and serial number. You can find this information on the type plate. You can write down the information here in these instructions so that you have them at hand. This makes it easier for the service technician to find the correct spare parts.

The warranty does not cover:

- Faults and damage that are not due to manufacturing or material issues
- Damage caused by failure to properly maintain the device - including failing to clean it
- Fire and/or water damage or moisture damage on the product
- Damage caused during transport if the product was transported without proper packaging
- Damage caused by the use of unoriginal spare parts
- Damage resulting from failing to follow the instructions on how to use the device
- If the device has not been set up/assembled as specified in the instructions
- If non-professionals have installed or repaired the product
- Batteries or any other parts subject to normal wear and tear

Damage during transport

If the product is damaged during transport and this is discovered when the retailer delivers the product to the customer, this is exclusively a matter between the customer and the retailer. In cases where customers have handled the transport of the product themselves, the supplier shall not be liable for any potential damage during transport. Any damage caused during transport must be reported immediately and no later than 24 hours after the product has been delivered. If not, the customer's claim will be rejected.

Unnecessary service

If the product is sent in to be serviced and it turns out that the fault could have been fixed independently by following the product's instruction manual, the customer will need to pay the service fee.

Commercial purchases

Commercial purchases are all purchases of devices that are not intended to be used in private households but instead intended to be used for commercial purposes (in restaurants, cafés, canteens, etc.) or intended to be rented out or otherwise used by multiple users in turn.

There is no warranty offered for commercial purchases, as this product is only intended for regular household use.

Service

For service and spare parts in England and Ireland please call below-mentioned number and you will be directed accordingly or send us an email.

Witt UK & Ireland Ltd.

(44) 148 351 6633 / info@witt.dk

If you want to use a service technician or get spare parts in Denmark, please contact the store that you bought the product from.

You can also claim warranty at witt.dk under the 'Service' tab.

We accept no liability for printing errors.

The manufacturer/distributor cannot be held liable for damage to products or individuals if the safety instructions were not followed. The warranty shall not cover cases where the instructions have not been followed.

