

# Roomba® Plus 410-419 Combo Robot + AutoWash™ Dock

---

Owners Guide

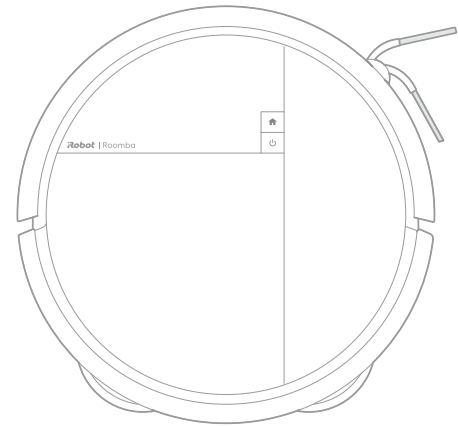

# Getting Started

1

## Download the Roomba® Home App



Scan the QR code with the camera on your mobile device or find the Roomba® Home App in your App store.

The Roomba® Home App and a Wi-Fi® connection are **required to complete set up**. The Roomba® Home App will guide you through steps to set up your robot.

Once your robot is set up, you can use the app to:

- Control when, where, and how you clean
- Create automatic cleaning schedules
- Set custom cleaning preferences
- Unlock digital features
- Access to tips, tricks, and answers to commonly asked questions

### NOTE:

2.4 GHz Wi-Fi must be used.

### IMPORTANT:

Read safety information guide first before using your robot.

2

## Remove Protective Packaging

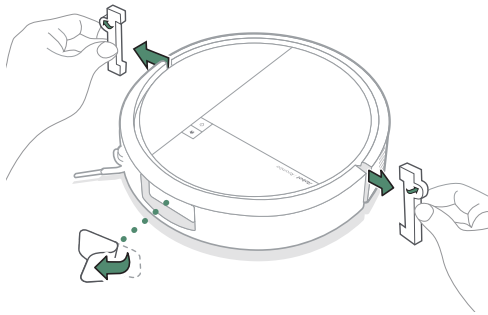

Remove protective film from ClearView™ LiDAR screen and foam inserts from behind the bumper.

3

## Install the Edge-Sweeping Brush and Mop Pads

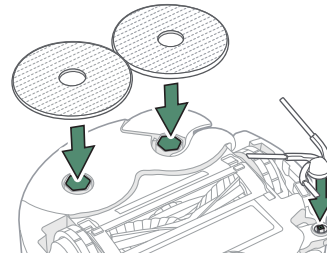

Align the Edge-Sweeping Brush and press down until you hear a click.

4

## Place Your Dock

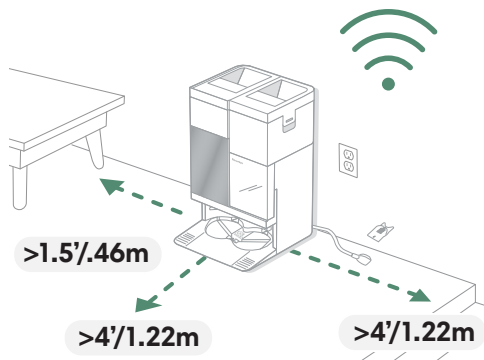

Place your dock on hard, level surfaced flooring.

### NOTE:

Do not place it in direct sunlight. Ensure the area around the dock is free of clutter to improve docking performance.

### WARNING:

To prevent the risk of your robot falling down stairs, ensure that your dock is placed at least 4 feet (1.22 meters) away from stairs.

5

## Plug in Your Dock

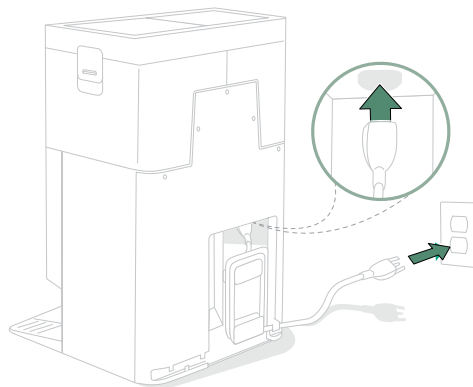

Plug the Power Cord into the back of the dock, then into a wall outlet. Wrap the cord on the back so it won't get in the way of the robot as it comes and goes.

6

## Fill the Clean Water Tank

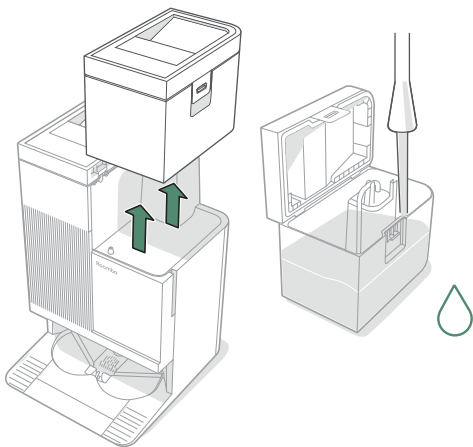

Remove Clean Water Tank from dock. Fill the Clean Water Tank with water and compatible cleaning solution if desired.

### NOTE:

A list of compatible cleaning solutions can be found here: <https://homesupport.irobot.com/s/article/roomba-combo-cleanser> or by visiting the app.

### IMPORTANT:

Ensure the latch is properly closed before reinstalling, and that tanks are properly seated to prevent leaks.

7

## Wake Up Your Robot

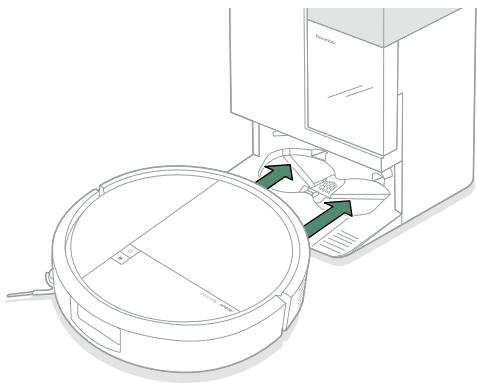

Place your robot in front of the dock, then slide it forward until the metal Charging Contacts are lined up. Its lights will indicate that it's waking up. A sound will let you know it's fully awake.

### **NOTE:**

Your robot comes with a partial charge, but we recommend letting it charge for 6 hours prior to creating a map of your home as battery readings may be inaccurate for the first few days.

# About your Roomba® Plus 410-419 Combo with AutoWash™ Dock

## Top View

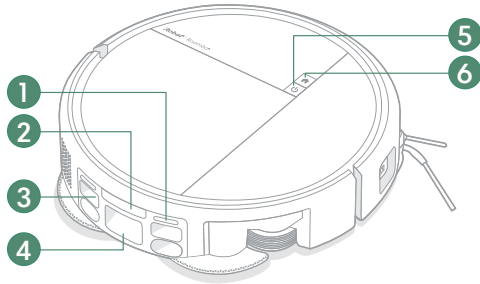

1. Charging Contact(s)
2. Rear Recharging IR Lamp
3. Dock Alignment Mechanism(s)
4. Debris Evacuation Port
5. Power Button
6. Home Button
7. Robot Top Plate

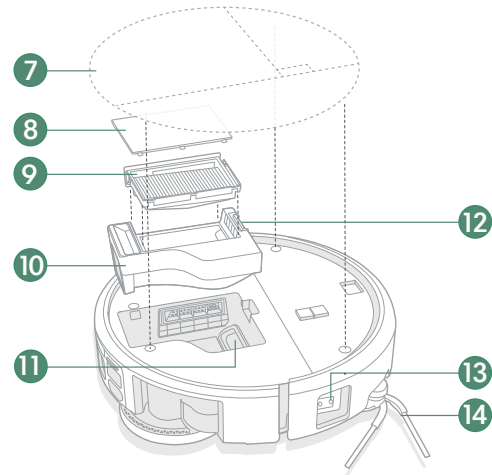

7. Robot Top Plate
8. Filter Cartridge Cover
9. Filter Cartridge
10. Dust Bin
11. Debris Evacuation Port
12. Dust Bin Release Button
13. Edge-Following IR Sensor
14. Edge-Sweeping Brush

## Bottom View

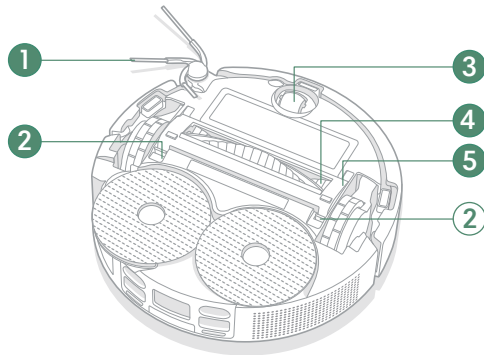

1. Edge-Sweeping Brush
2. Multi-Surface Brush Cover Release Tabs
3. Caster Wheel
4. Multi-Surface Brush
5. Multi-Surface Brush Cover

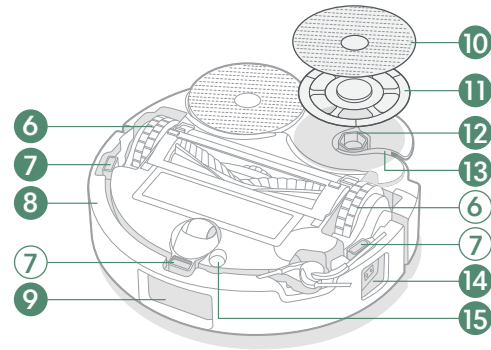

6. Wheels
7. Sensors
8. Bumper
9. ClearView™ LiDAR
10. Dual Spinning Mop Pad
11. Dual Spinning Mop Pad Plate
12. Dual Spinning Mop Pad Plate Attachment Port
13. Dual Spinning Mop Pad Plate Extension Arm
14. Edge Following IR Sensor
15. Carpet Sensor

# About your AutoWash™ Dock

## Front View

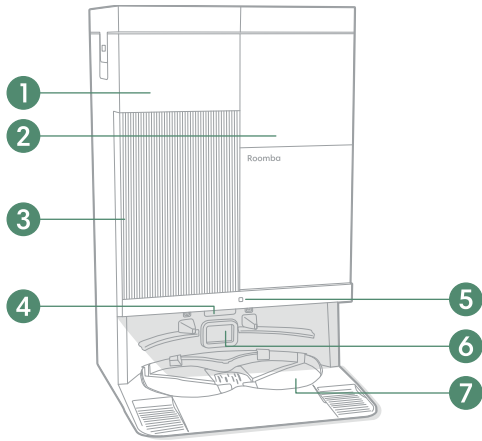

1. Dirty Water Tank
2. Clean Water Tank
3. Cubby Door
4. IR Window
5. LED Indicator
6. Debris Evacuation Port
7. Wash Basin

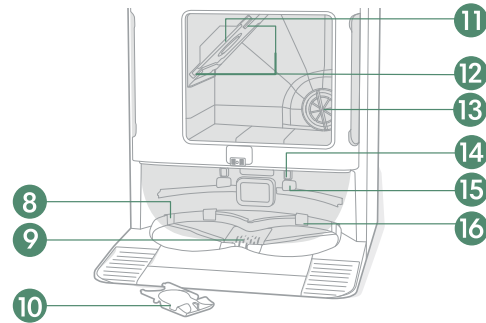

8. AutoWash™ Water Inlet
9. AutoWash™ Water Drain
10. Debris Guard
11. Dirt Disposal Bag
12. Bag Alignment Mechanisms
13. Dock Filter
14. Charging Contacts
15. Dock Alignment Guides
16. Hot Air Duct

## Rear View

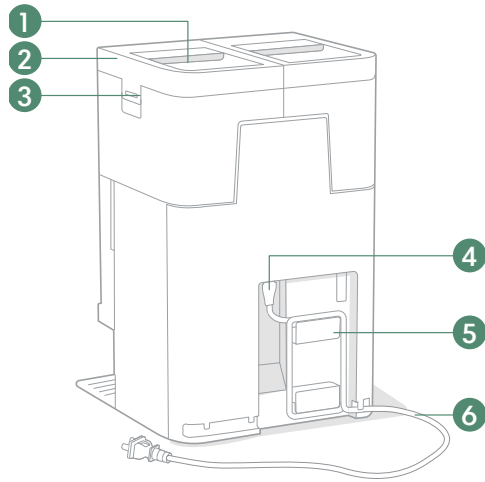

1. Water Tank Handle
2. Water Tank Lid
3. Water Tank Latch
4. Cord Attachment
5. Cord Wrap
6. Removable Power Cord

## Top View

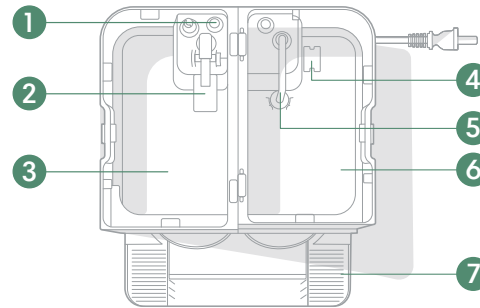

1. Water Entry Point
2. Dirty Water Float
3. Dirty Water Tank
4. Clean Water Float
5. Clean Water Tubing
6. Clean Water Tank
7. Wheel Tracks

# Charging

## Icon Indicators

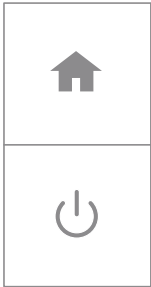

### POWER and HOME Buttons

**White:** Fully charged and connected.

**Flashing White:** Returning to dock to charge.



**Pulsing White:** Charging / Low Battery. When robot battery falls below 20% and is charging or on its way to charge.

**Flashing Red:** Error / Low Battery. When robot has an error or when it's off the dock and its battery falls below 20%.

## Charging your Robot

Your robot will return to the dock whenever it needs to recharge during a cleaning routine. Once it is sufficiently charged, it will then resume cleaning where it left off.

## Standby Mode

Your robot uses a small amount of power whenever it is on the dock. You can put it in a further-reduced power state when not in use by pressing  for 10 seconds. To exit low power mode short press .

### NOTE:

Cleaning cannot be started from the mobile app while in low-power mode.

## Storing your Robot

For long-term storage, turn off your robot by removing it from the dock, then press and hold the  button and bumper together for 10 seconds. Store in a cool, dry place.

## Dock LED Indicator

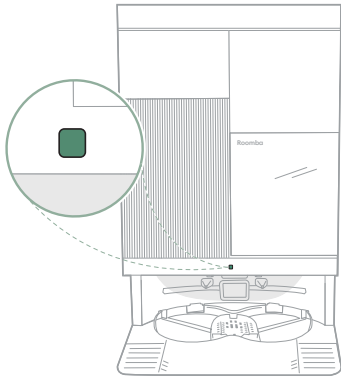

### NOTE:

Software updates may adjust the actual LED behavior on the robot and/or dock. Please visit [global.irobot.com](https://global.irobot.com) for the most up-to-date information.

### **SOLID WHITE:**

- Charging
- Dock Standby Mode or evacuating
- Mop Washing and Pad Drying
- Robot Clean Water Tank is being filled

### **SOLID RED:**

- Dust Bag full, missing, or improperly installed
- Dirty Water Tank full, missing, or improperly installed
- Clean Water Tank empty, missing, or improperly installed
- Wash Basin full

# Cleaning

## Button Controls

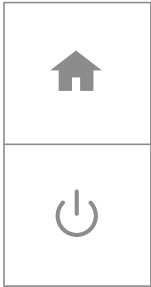

### HOME

- Tap to send the robot home
- Press to pause cleaning
- Press when paused to dock
- Press to stop docking

### POWER

- Tap to Start / Pause / Resume Cleaning
- Hold for 3 seconds to turn on
- Hold for 10 seconds to turn off

### NOTE:

Roomba® robots are generally designed to be used on most floor types for vacuuming. We do not recommend using mopping functions on unsealed hardwood floors and certain laminate / vinyl planks due to potential water damage to the flooring and/or subfloor. For more info, please visit [global.irobot.com](https://global.irobot.com).

## Cleaning Pattern

Your robot will automatically explore and clean your home. It will start by cleaning the perimeter of the room and then clean the remaining floor space in neat rows. It will return to the dock at the end of a cleaning routine and whenever it needs to re-charge.

### Tips:





- Remove excess clutter from floors before cleaning.
- Use your robot frequently to maintain well-conditioned floors.

After 90 minutes of inactivity off the dock, your robot will automatically end its cleaning. If you are unsure if it is finished or paused, visit the Roomba® Home App to check on its status.

## Spot Clean

You can Spot Clean from the Roomba® Home App or your robot.

Place your robot near the designated area you need Spot Cleaned. Tap  two times. Spot Clean will clean 1m x 1m square around the robot two times in perpendicular directions. After Spot Clean is complete, your robot will end its cleaning routine. Press  to send it back to its dock.

## Auto-Emptying

Your robot will automatically empty its Dust Bin at the end of each cleaning routine.

## Auto-Washing

Your robot will automatically return to the AutoWash™ Dock to wash its pads as needed during Mop only and Vac & Mop tasks.

## Mop Pad Plate Extension Arm

The Dual Spinning Mop Pad Plate Extension Arm ensures that your robot can reach tucked away spaces like recessed edges, corners, or other hard to reach spots.

### NOTE:

It is highly recommended to use the Roomba® Home App for cleaning control. The mobile app can be used to clean specific rooms, set up cleaning routines, and create automations and schedules.

## Pad Washing and Pad Drying

Your robot will return to its dock for Pad Washing as needed during cleaning routines and then again when finished.

Pad drying will only take place at the end of its cleaning routine.

Once complete, the dock will proceed to dry the Mop Pads by blowing forced heated air over them.

Visit the Roomba® Home App to manually start Pad Washing, start or stop Pad Drying, or to customize Pad Washing settings.

### IMPORTANT:

Do not interrupt the robot while Pad Washing is active. It is normal to hear noises throughout this process as the pads spin and the Wash Basin is filled and drained.

### NOTE:

The drying process can last for a few hours. You can choose from different drying times in the app. You may hear a low hum coming from the dock while the dryer is active.

# Vacuuming & Mopping

To start cleaning, place the robot on the dock and use the app or press  to start.

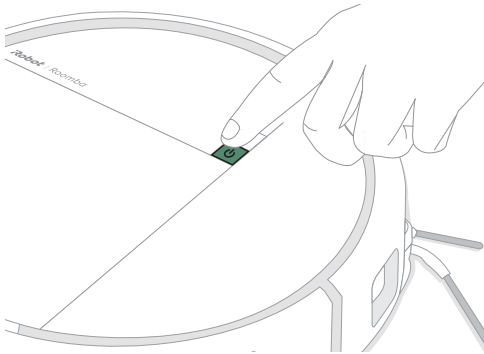

## Initiate Vacuum Mode

To vacuum, ensure robot is on the dock. Use the Roomba® Home App to select rooms / spaces, select Vacuum Mode and start your cleaning routine.

## Initiate Mop or Vac & Mop Mode

To Mop or Vac & Mop, ensure Clean Water Tank is full, Dirty Water Tank is empty, and the robot is on the dock or ground with the Mop Pad Plates and Mop Pads installed. Press  to

initiate a Vac & Mop routine or use the Roomba® Home App to select rooms / spaces, select Vac & Mop, Vac then Mop or Mop only and start your routine.

### NOTE:

Your robot uses Vacuum & Mop combo cleaning mode by default. To Vacuum only, Mop only, select rooms to clean, and customize your cleaning routine use the Roomba® Home App.

## Starting a cleaning routine from your dock

If the Clean Water Tank and Dirty Water Tanks are ready, skip to step 5. If the Clean Water Tank or Dirty Water Tank LED Indicators are on:

1

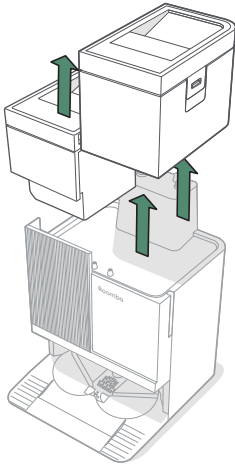

Lift to remove the tank that requires maintenance.

2

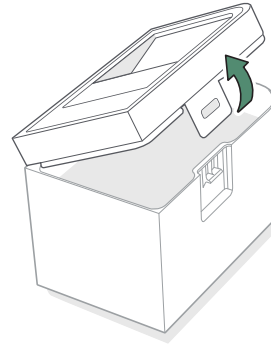

Lift the latch on the tank to open.

3

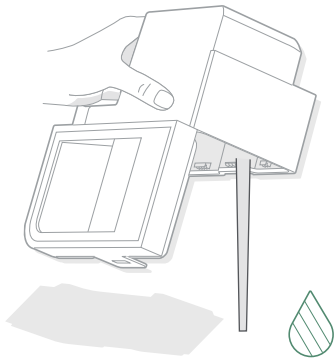

Empty the Dirty Water Tank.

4

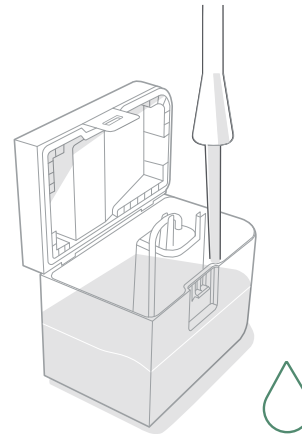

Fill the Clean Water Tank with water.

 **NOTE:**

A list of compatible cleaning solutions can be found here: <https://homesupport.irobot.com/s/article/roomba-combo-cleanser> or by visiting the app.

5

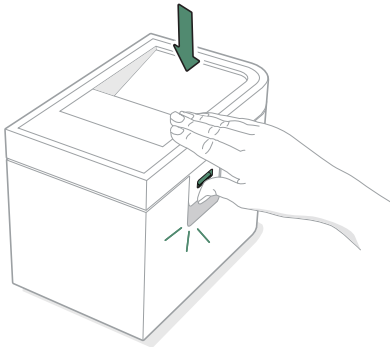

Close and latch the water tank lids.

6

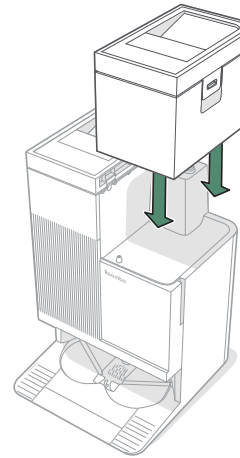



Place tanks back on the dock.

**\* IMPORTANT:**

Ensure the latch is properly closed before reinstalling, and that tanks are properly seated to prevent leaks.

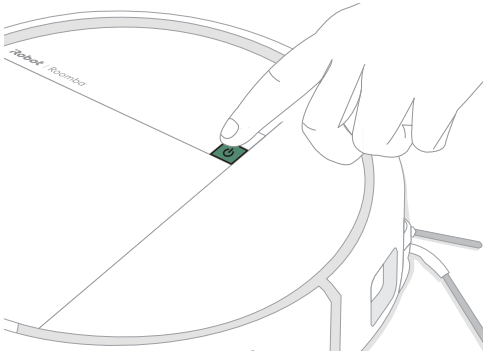
7



With Mop Pads attached, return the robot to the AutoWash™ Dock and use the app or press the  button on your robot.

 **IMPORTANT:**

Your robot is able to both vacuum and mop at the same time when the Mop Pad Plate(s) and Mop Pad(s) are installed. Before starting a cleaning routine, prepare the room by rolling up / removing any carpets in the area you want to mop.

# Care and Maintenance for your Robot

Maintain optimal performance and debris pick-up by regularly cleaning the parts in the chart below. If you notice your robot leaving debris behind, empty the bin, and clean the filter and brushes.

View additional instructional videos in the Roomba® Home App.

Part	Care Frequency	Replacement <sup>a</sup>
Mop Pad Plate(s)	Automatically cleans after each use	Replace if worn or damaged
Mop Pad(s)	Automatically cleans and dries after mopping	Every 3-6 months
Water Tank	Empty after each use	
Dust Bin	Empty and wash as needed	
Multi-Surface Brush	Clean 1/week	Every 6-12 months
Charging Contacts	Clean every 2 weeks or as needed	
Edge-Sweeping Brush	Clean every 2 weeks or as needed	Every 3-6 months
Filter	Clean 1/week (2/week with pet)	Every 3-6 months
Caster Wheel	Clean every 2 weeks or as needed	
Sensors	Clean 1/month or as needed	
Brush Cover	Inspect every 6 months	Replace if worn or damaged

<sup>a</sup>Replacement frequency may vary. Parts should be replaced if visible wear appears. If you think you need a replacement part, please contact iRobot® Customer Care for more information.

## Cleaning the Edge-Sweeping Brush

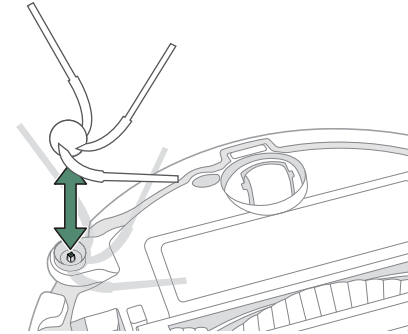

Pull Edge-Sweeping Brush to remove. Remove any hair or debris. Reinstall Edge-Sweeping Brush.

### **\* IMPORTANT:**

It is recommended to replace the Edge-Sweeping Brush every 3-6 months for optimal cleaning.

## Cleaning the Multi-Surface Brush

1

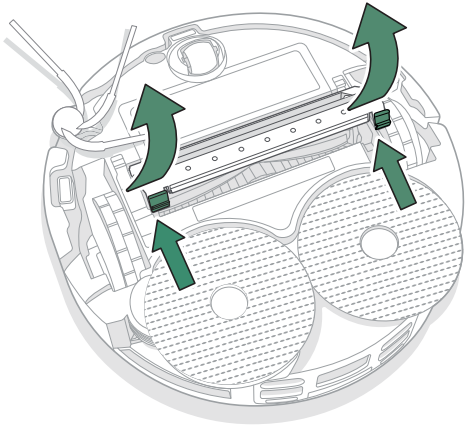

Press the Multi-Surface Brush Frame Release Tabs and lift to remove brush frame.

2

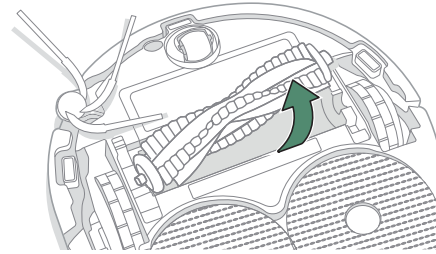

Remove the Multi-Surface Brush.

3

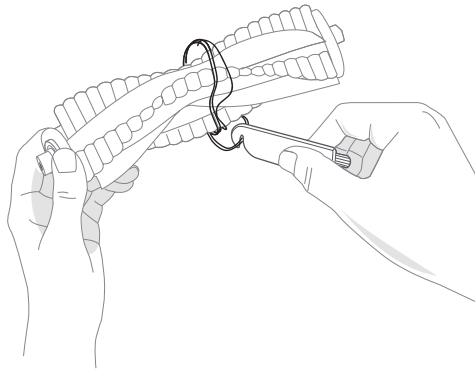

Remove any hair or debris.

4

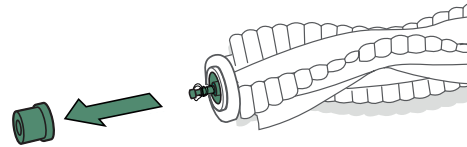

Remove end cap from the end of the brush.

5

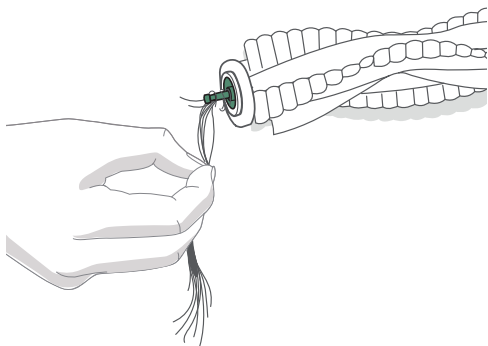

Remove any hair or debris that has collected beneath the cap. Replace end cap.

6

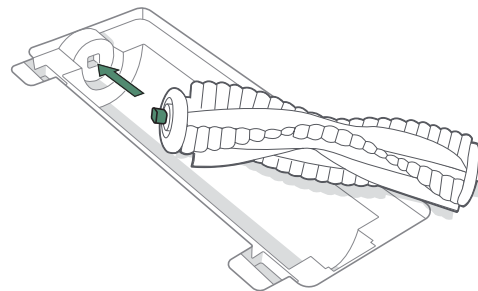

Reinstall the Multi-Surface Brush and Brush Cover in the robot.

**\* IMPORTANT:**

It is recommended to replace the multi-surface brush every 6-12 months for optimal cleaning performance.

**☰ NOTE:**

For instructions to perform a deeper cleaning of the Multi-Surface Brush, see [global.irobot.com](https://www.irobot.com).

## Cleaning the Front Caster Wheel

1

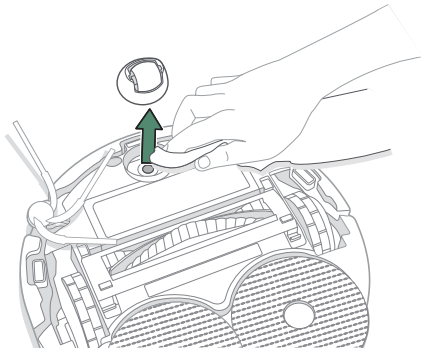

Lift up to remove the Caster Wheel from your robot.

Use a cloth to remove hair and debris from beneath the Front Caster Wheel.

2

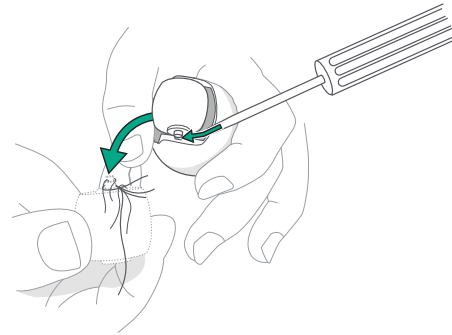

Use a flathead screwdriver to pry out the wheel, and remove from the caster.

3

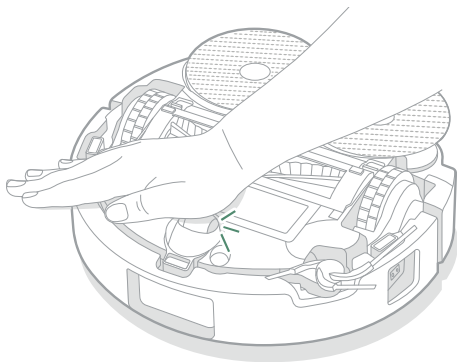

To reinsert the Caster Wheel, firmly press down with your palm until you hear a click.

**\* IMPORTANT:**

A front wheel clogged with hair and debris could result in damage to your floor. If the wheel is not spinning freely after you have cleaned it, please contact Customer Care.

## Cleaning the Charging Contacts and Sensors

Remove the robot from the dock and wipe the Charging Contacts and Sensors with a clean, dry cloth or lightly dampened melamine foam.

### CHARGING CONTACTS

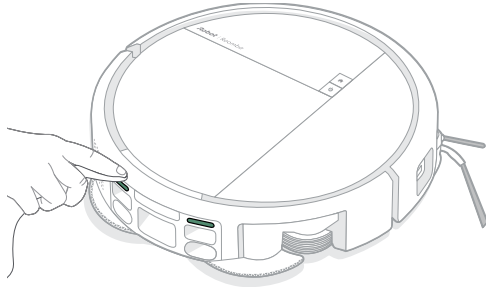

### SENSORS

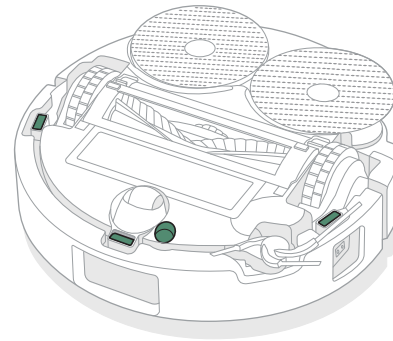

#### **\* IMPORTANT:**

Do not spray cleaning solution or water on the Sensors or Sensor openings.

## Cleaning the Filter and Dust Bin

1

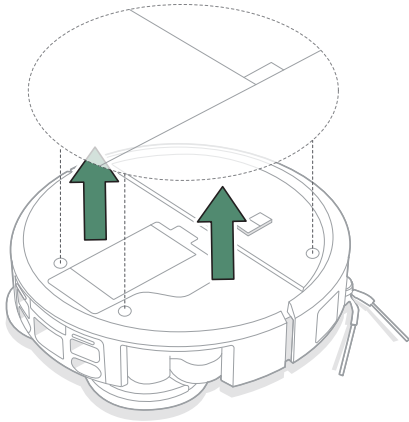

Remove Robot Top Cover by lifting up.

2

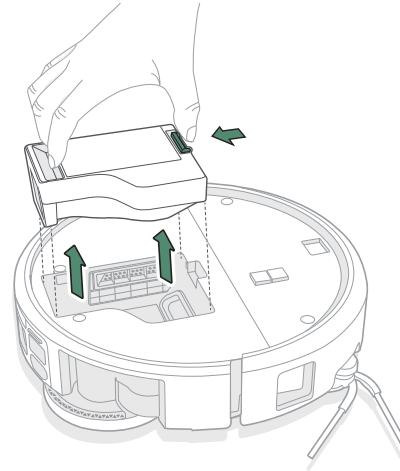

Press the Dust Bin Release Button and pull up to remove Dust Bin.

3

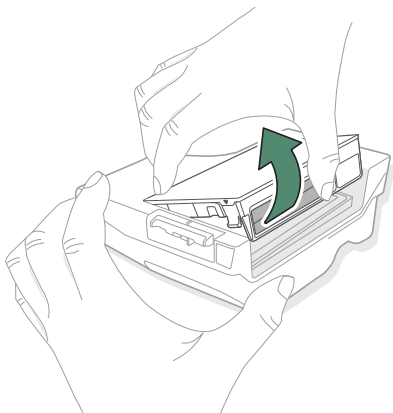

Remove Filter Cartridge.

4

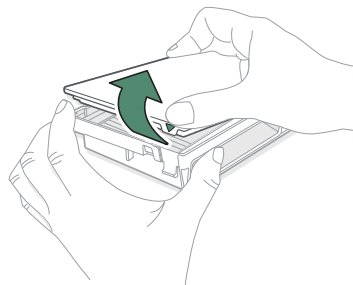

Remove Filter Cartridge Cover.

5

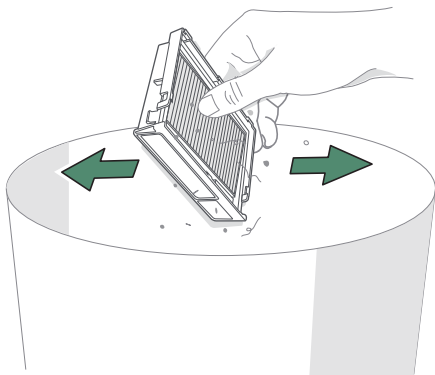

Remove debris by tapping filter against trash bin and/or clean with clean cloth.

6

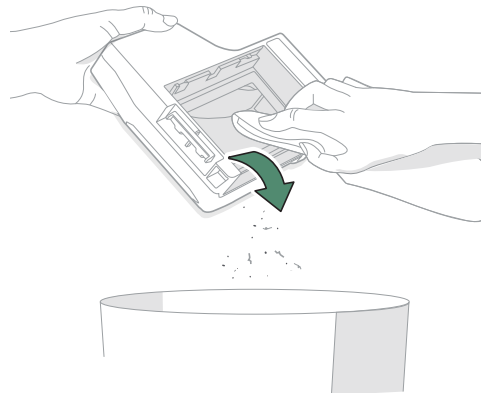

Empty Dust Bin over a trash bin and clean with cloth, or rinse using warm water.

**\* IMPORTANT:**

Do not wash the filter. Remove the filter before washing the bin. The bin is not dishwasher safe.

7

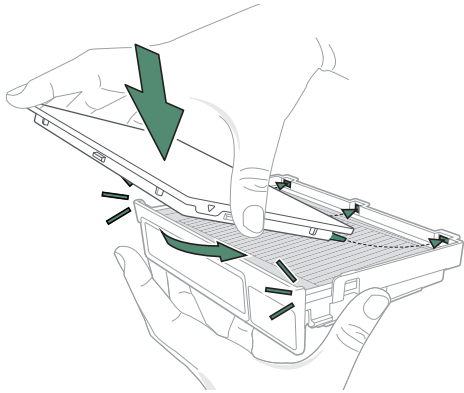

Reinstall Filter Cartridge Cover.

8

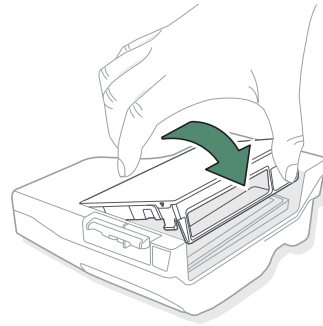

Return Filter Cartridge onto Dust Bin.

9

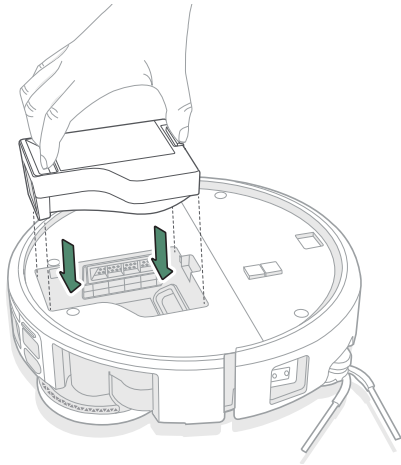

Place Dust Bin back in the robot.

10

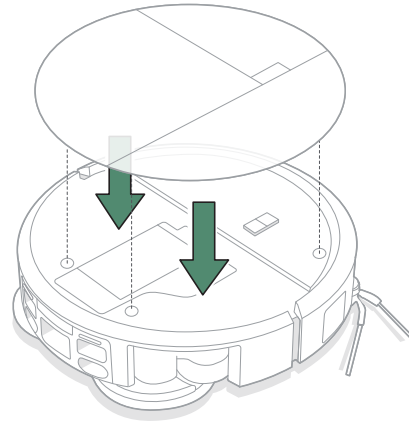

Return Robot Top Cover.

# Care and Maintenance for your AutoWash™ Dock

To keep your AutoWash™ dock operating at optimal performance, perform the following care and maintenance tasks.

Part	Care Frequency	Replacement Frequency <sup>a</sup>
Charging Contacts	Once every month	
Clean Water Tank	Rinse and refresh water as needed	
Dirt Disposal Bags		Bags should be replaced when full - prompted by the LED indicator on the AutoWash™ Dock and/or Roomba® Home App
Dirty Water Tank	Rinse and empty as needed	
Dock Filter	Each month remove debris covering the dock filter	
IR Window	Clean once a month	
Sensors	Clean once a month	
Wash Basin and Air Duct	Clean every 2 weeks or as needed	

<sup>a</sup>Replacement frequency may vary. Parts should be replaced if visible wear appears. If you think you need a replacement part, please contact iRobot® Customer Care for more information.

## Cleaning the Charging Contacts and IR Window

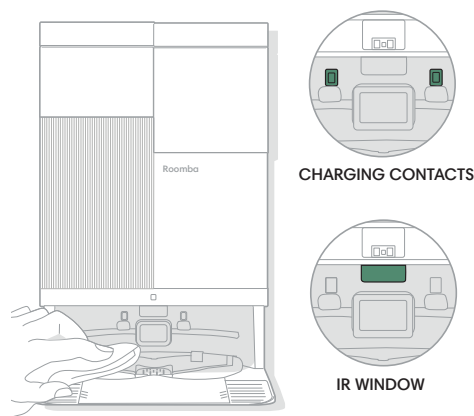

Unplug the dock. Inspect the components to make sure that they are clear of debris. Wipe with a clean dry cloth.

### **\* IMPORTANT:**

Do not spray cleaning solution or water on the Sensors or Charging Contacts.

## Washing the Water Tanks

1

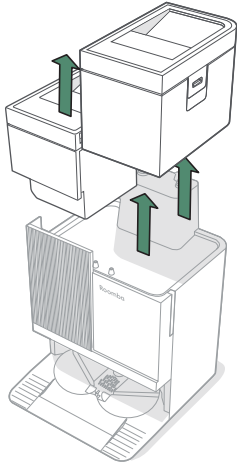

Remove both water tanks.

2

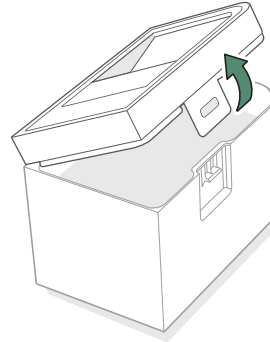

Lift the latch on the water tanks to open.

3

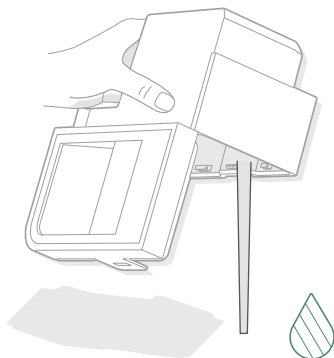

Empty Dirty Water Tank.

4

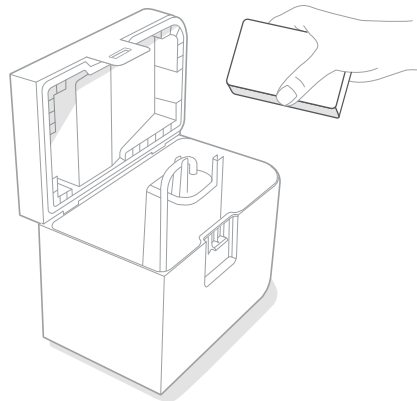

Rinse both water tanks using warm water. Mild soap and a sponge may be used for stubborn debris.

**\* IMPORTANT:**

Water tanks are not dishwasher safe.

5

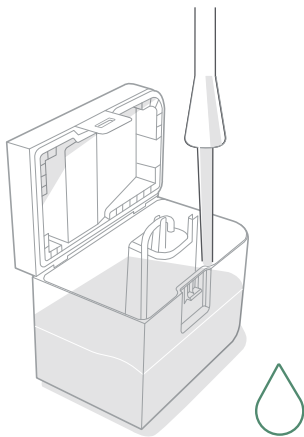

Refill the Clean Water Tank with water. Leave the Dirty Water Tank empty.

6

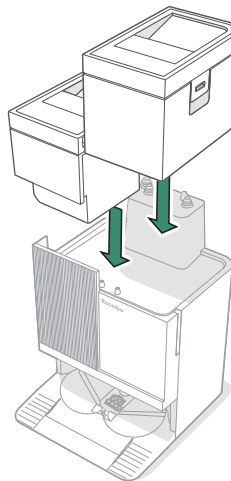

Reinsert both water tanks.

**\* IMPORTANT:**

Ensure the latch is properly closed before reinstalling.

## Replacing the Dirt Disposal Bag

1

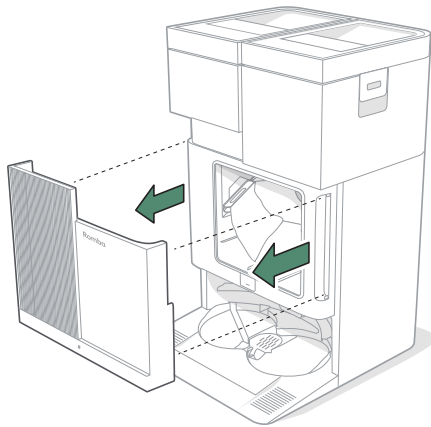

Remove Cubby Door.

2

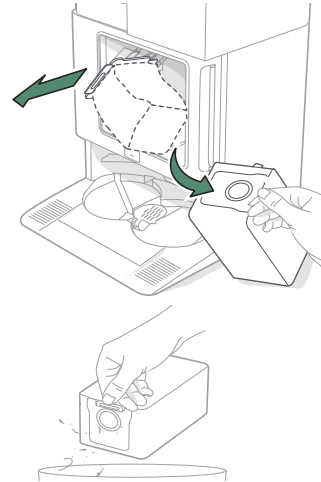

Remove the Dirt Disposal Bag by pulling the card from the dock. This will seal the bag so dust and debris cannot escape.

3

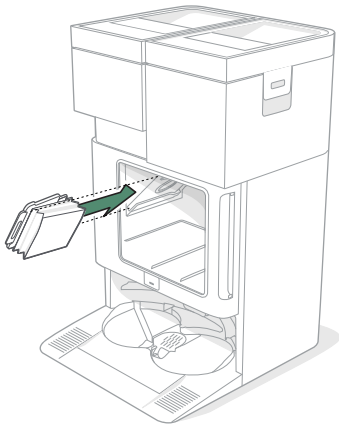

Install a new Dirt Disposal Bag by sliding the card into the guide rails.

4

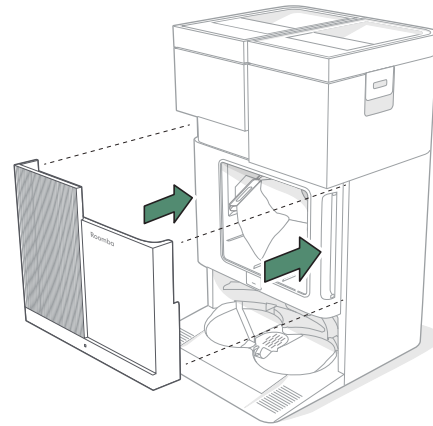

Return the Cubby Door.

## Removing Debris from Dock Filter

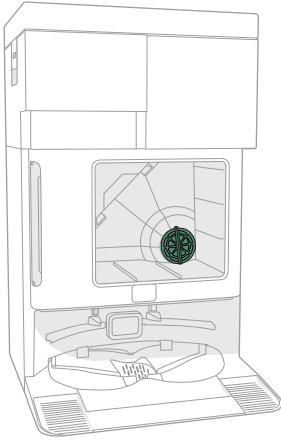

Remove Cubby Door. Inspect blower cover for any lint or debris build-up, and wipe with a clean dry cloth to remove debris. Return Cubby Door.

## Clean Wash Basin and Debris Guard

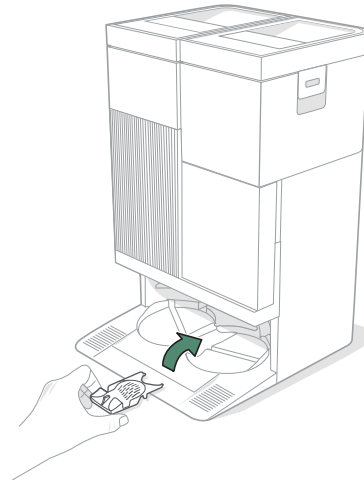

Remove the Debris Guard. Wipe out the Water Basin. Rinse or wipe clean the Debris Guard. Reinsert the Debris Guard, making sure it is properly nested, face up.

### NOTE:

If it is not installed correctly it may prevent the mop from being cleaned properly.

# Troubleshooting

## Troubleshooting your Robot

Your robot will alert you if something is wrong with a voice announcement or audio alert. The Roomba® Home App will also provide notifications with steps to troubleshoot any issues.

If you are unsure if the robot is finished or paused, consult the Roomba® Home App to check on its status.

## Factory Reset

To factory reset press  for 5 seconds, don't release, and then (within 5 seconds) press  +  for 5 seconds.

## Battery Safety and Shipping

- Battery **MUST** be turned off before shipping.
- To turn off battery, remove robot from the dock. Push in its bumper and hold it in that position while you press and hold the  button for 10 seconds, or until the lights turn off.
- Package the robot securely for shipping.

### **WARNING:**

Lithium ion batteries and products that contain lithium ion batteries are subject to stringent transportation regulations. If you need to ship this product for service, travel or any other reason, you **MUST** follow the below shipping instructions.

If you need further assistance, please visit your Roomba® Home App, contact iRobot® Customer Care or visit [global.irobot.com](https://global.irobot.com)

## Troubleshooting your AutoWash™ Dock

Your AutoWash™ Dock will tell you if something is wrong via an LED indicator on the front of the canister and through the Roomba® Home App. If the dock is not performing as expected, check the Roomba® Home App for troubleshooting steps.

LED Indicator	Common Error	How to Fix
Solid Red	Bag full or missing	Replace bag if it is full or missing.  Make sure that the bag is securely inserted.  If problem persists, remove any debris from the port on the back of your robot and front of the AutoWash™ dock.

### **NOTE:**

This product has been equipped with a thermal protector designed to protect against damage due to overheating. If the protector operates, the motor will stop running. If this happens, unplug the unit, allow it to cool for 30 minutes, clear any obstructions from the evacuation port and evacuation tube, then plug the unit back in.

### **Need further assistance? We're here to help.**

Download the Roomba® Home App or visit [global.irobot.com](https://global.irobot.com) for product support or to contact your local support center. If you need further assistance in the US & Canada, call the US Customer Care team at **(877) 855-8593**

### **iRobot® USA Customer Care Hours**

Monday to Friday, 9AM — 9PM Eastern Time

Saturday and Sunday, 9AM — 6PM Eastern Time

### **Safety Information**

Please see the safety guide that came with your robot, or visit [global.irobot.com](https://global.irobot.com)





©2026 iRobot Corporation. 8 Crosby Drive, Bedford, MA 01730 USA. All rights reserved. iRobot, Roomba, and PerfectEdge are registered trademarks of iRobot Corporation. AutoEmpty, AutoWash, StayClean, and PrecisionVision are trademarks of iRobot Corporation. Wi-Fi and the Wi-Fi logo are registered trademarks of Wi-Fi Alliance. Apple and App Store are trademarks of Apple Inc., registered in the U.S. and other countries. Google Play is a trademark of Google LLC.